



US 20070001936A1

(19) **United States**

(12) **Patent Application Publication** (10) **Pub. No.: US 2007/0001936 A1**
Kawakami et al. (43) **Pub. Date: Jan. 4, 2007**

(54) **DISPLAY DEVICE AND METHOD OF FORMING AND DRIVING THE SAME**

(30) **Foreign Application Priority Data**

(75) Inventors: **Haruo Kawakami**, Tokyo (JP); **Hisato Kato**, Tokyo (JP); **Keisuke Yamashiro**, Tokyo (JP)

Aug. 19, 2003 (JP) 2003-294919
Feb. 9, 2004 (JP) 2004-031541
Apr. 20, 2004 (JP) 2004-123650
May 21, 2004 (JP) 2004-151202

Correspondence Address:
ROSSI, KIMMS & McDOWELL LLP.
P.O. BOX 826
ASHBURN, VA 20146-0826 (US)

Publication Classification

(51) **Int. Cl.**
G09G 3/30 (2006.01)
(52) **U.S. Cl.** **345/76**

(73) Assignee: **FUJI ELECTRIC HOLDINGS CO., LTD.**, KAWASAKI (JP)

(57) **ABSTRACT**

An organic EL display device and method of forming and driving the same is matrix-driven by using a two-terminal nonlinear element. A display device having a substrate and first stripe electrodes, second stripe electrodes disposed crosswise to the first stripe electrodes, and a plurality of pixels disposed overlappingly between the first and second stripe electrodes on the substrate. Each pixel is provided with a switching element including a two-terminal nonlinear element connected electrically to the first stripe electrodes, a light-emitting portion connected electrically to the switching element and the second stripe electrodes, and a capacitor portion containing an organic dielectric material as a dielectric layer, connected electrically to the switching element and the second stripe electrodes in parallel with the light-emitting portion.

(21) Appl. No.: **10/569,257**

(22) PCT Filed: **Aug. 12, 2004**

(86) PCT No.: **PCT/JP04/11603**

§ 371(c)(1),
(2), (4) Date: **Apr. 11, 2006**

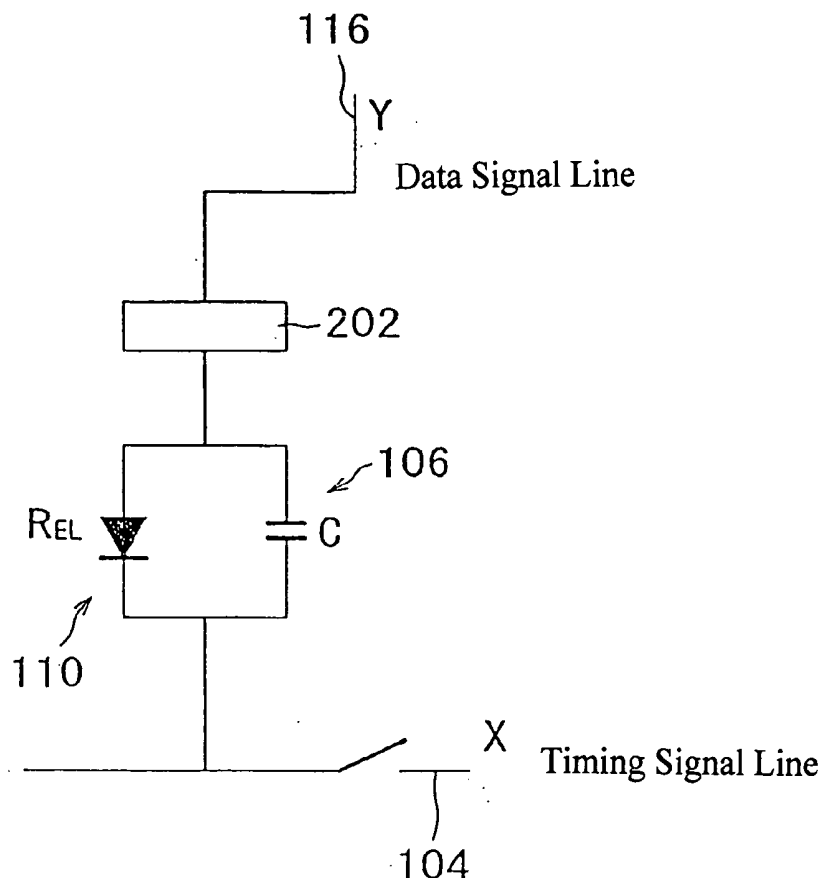

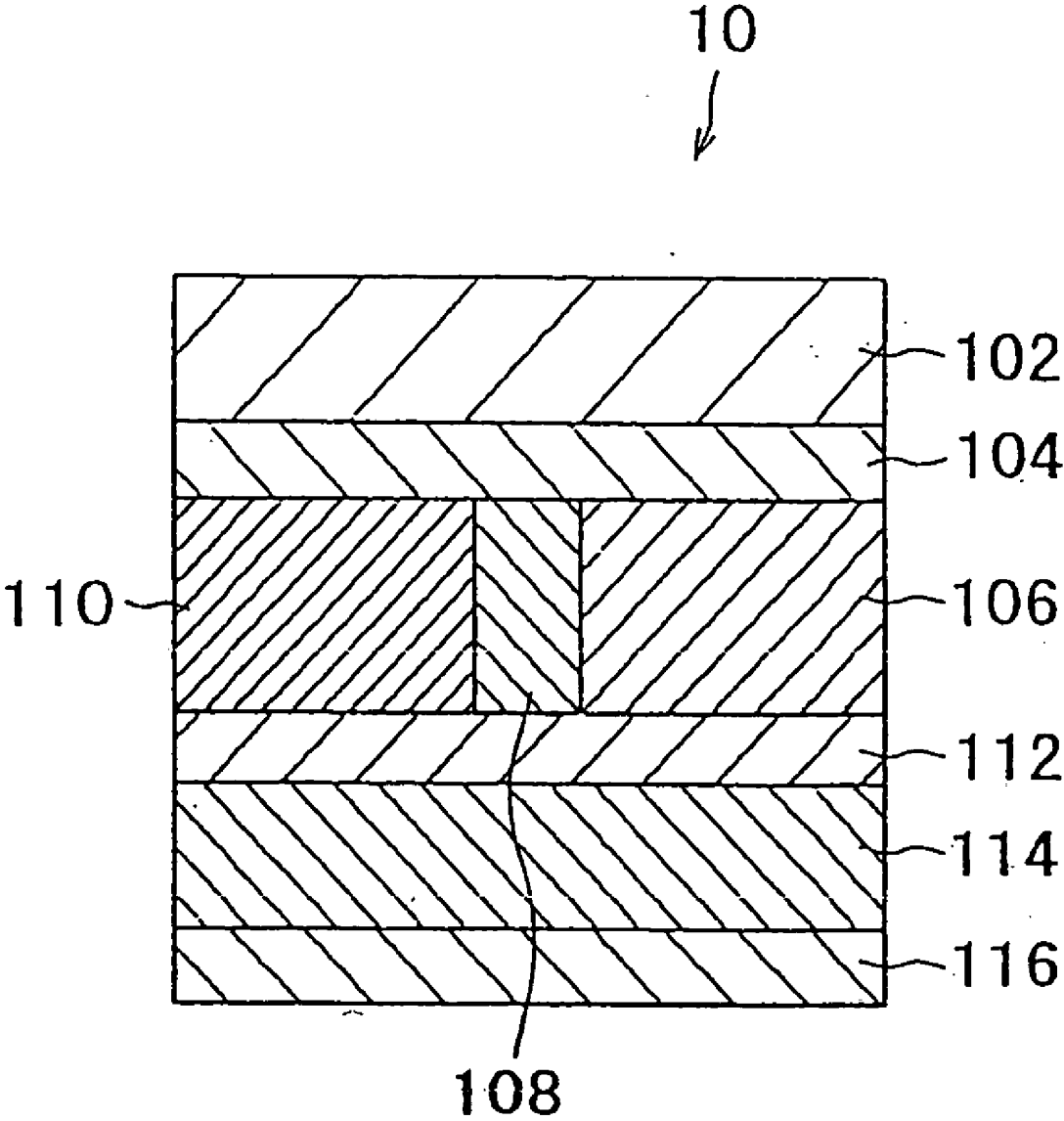

FIG. 1

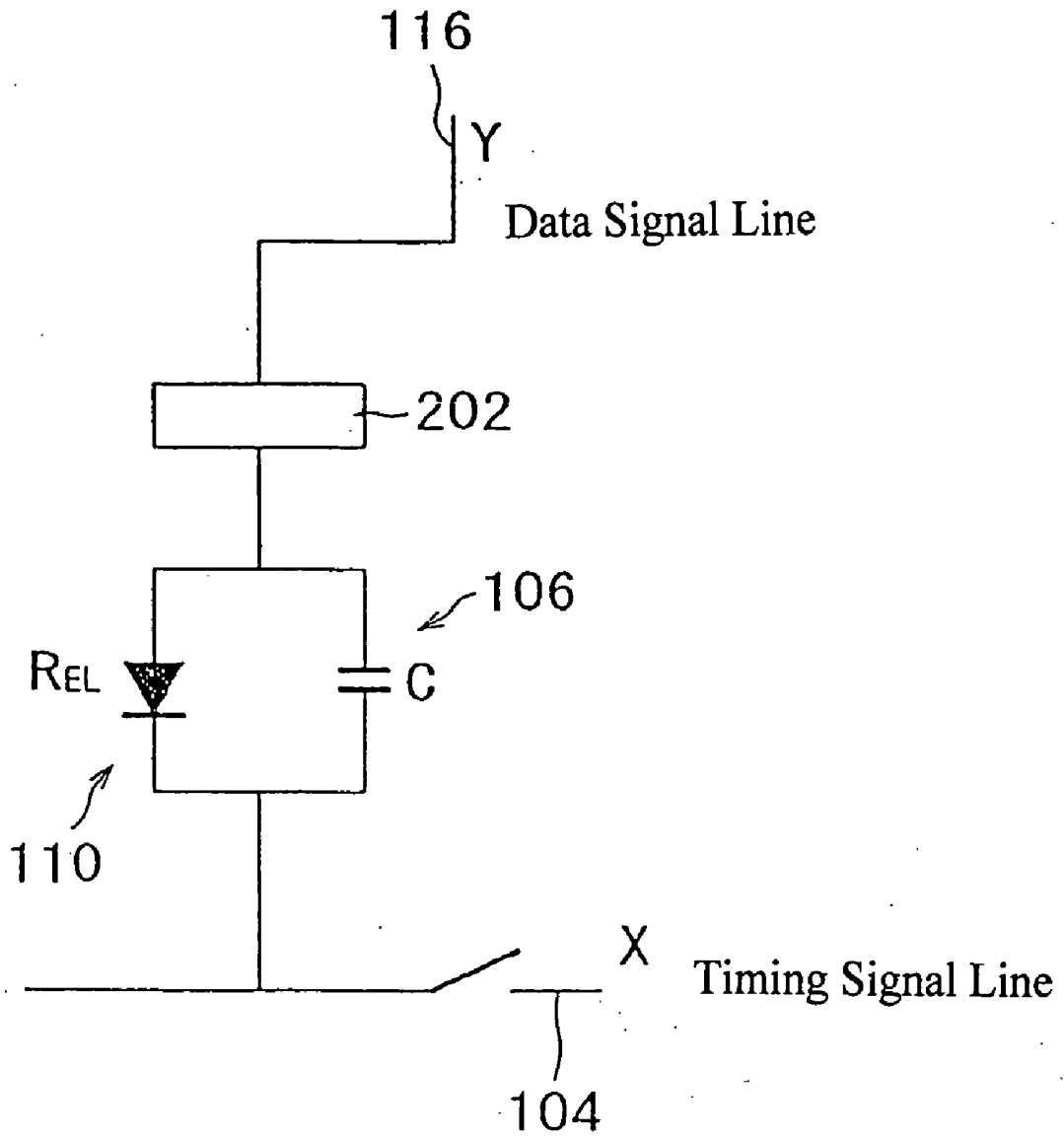
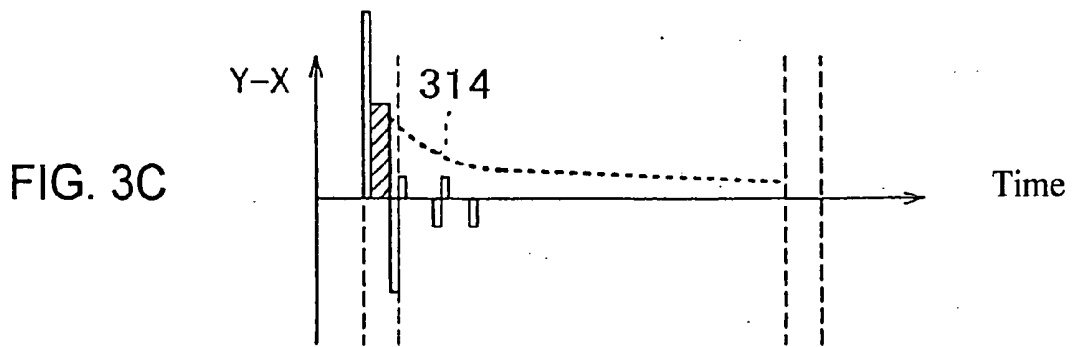
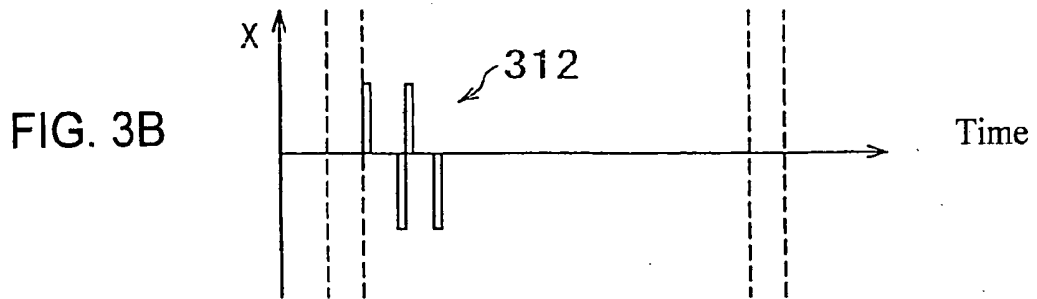
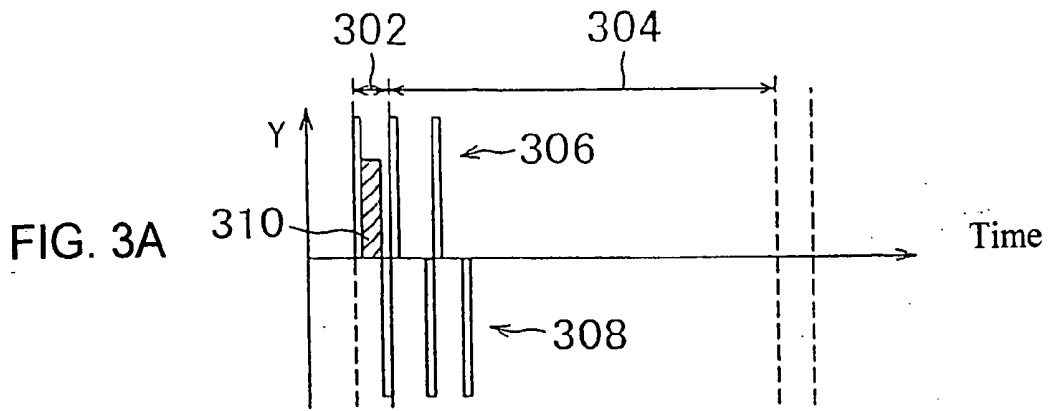

FIG. 2



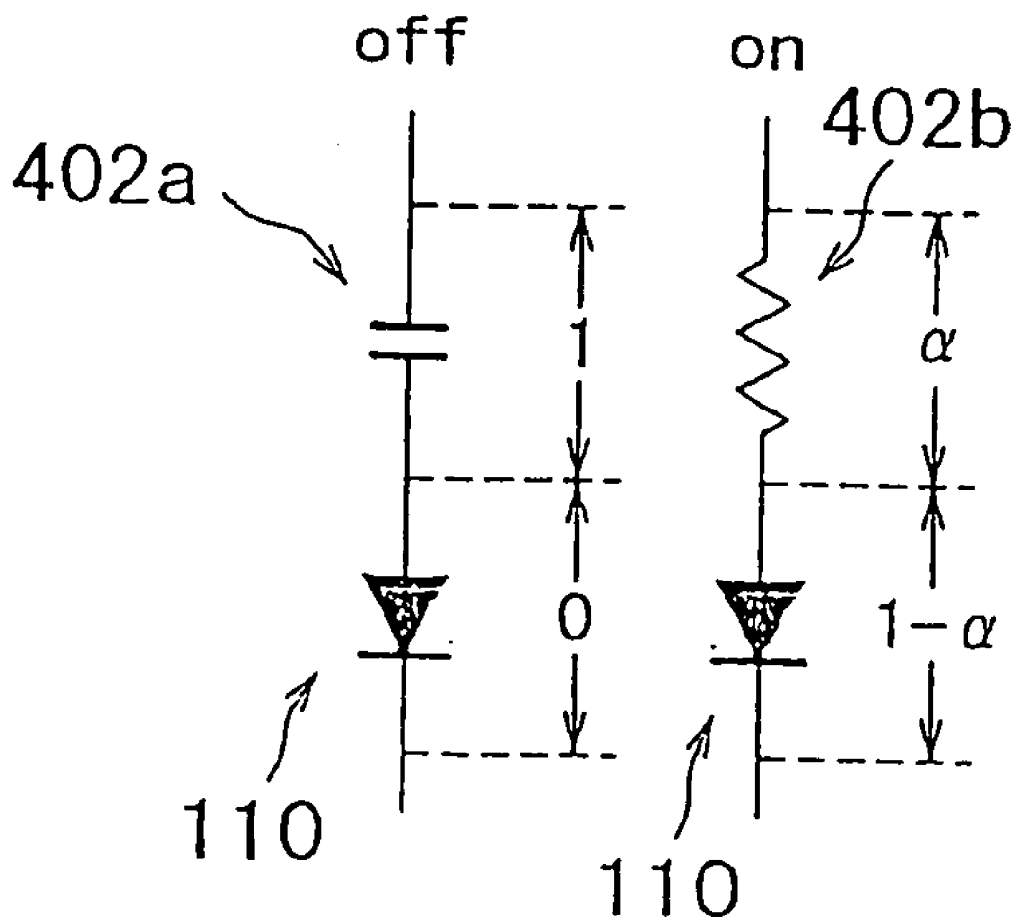

FIG. 4

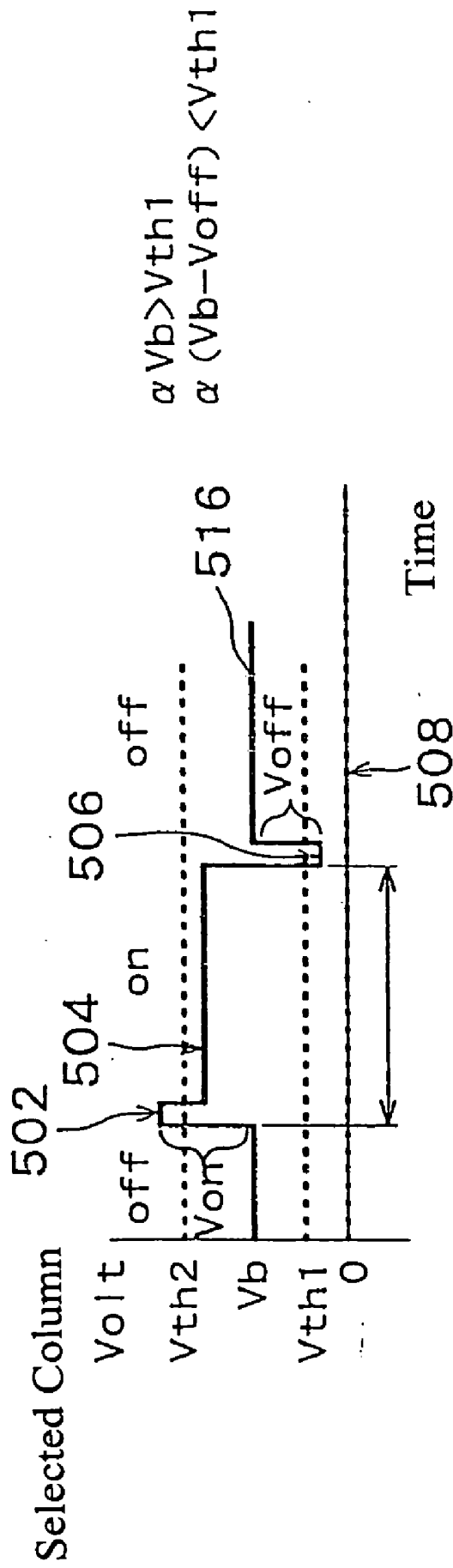

FIG. 5A

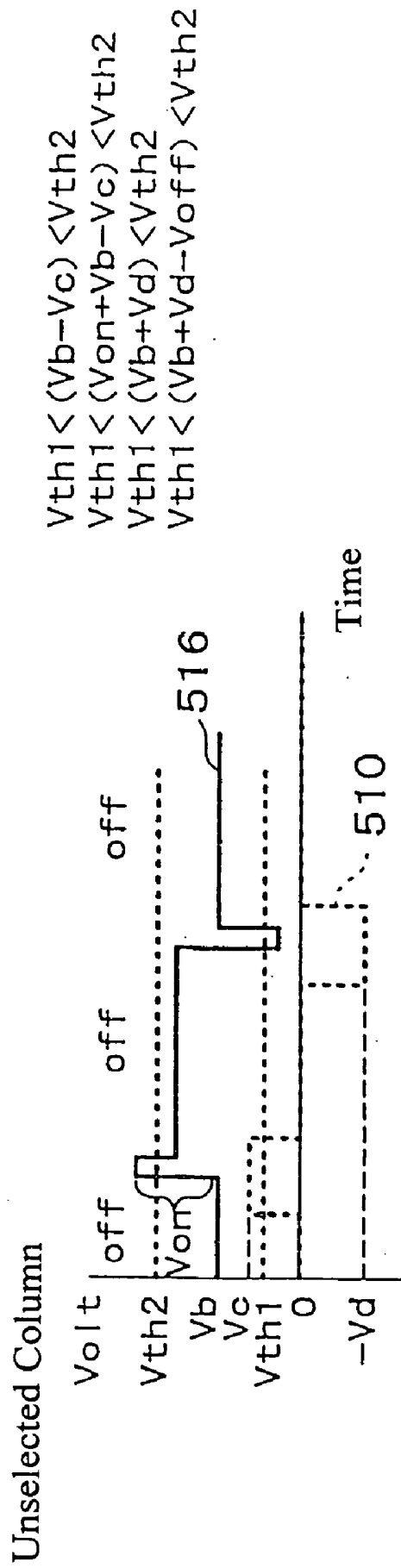
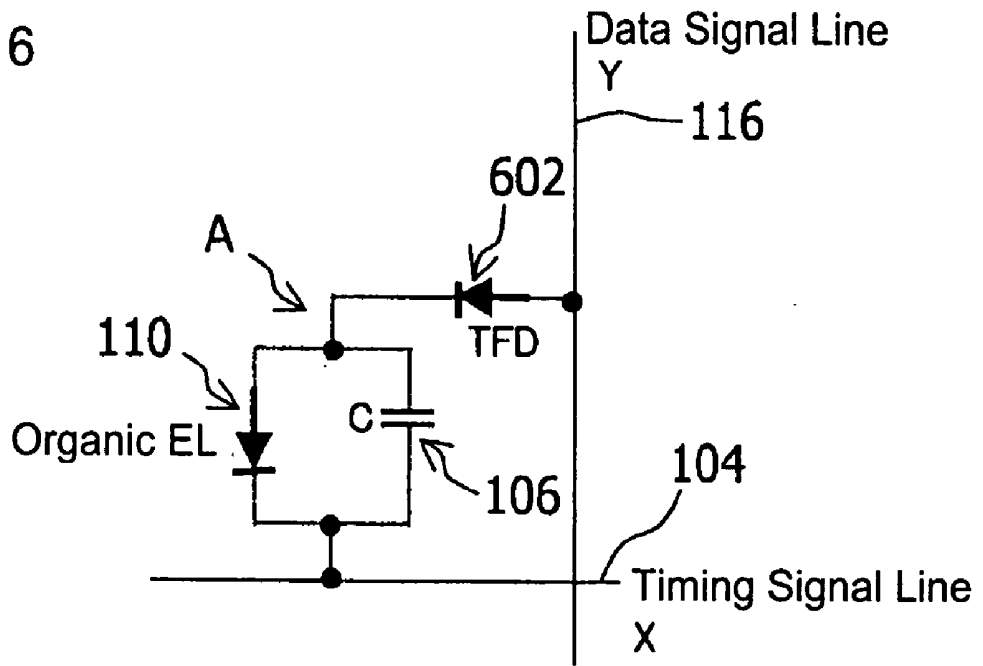

FIG. 5B

FIG. 6



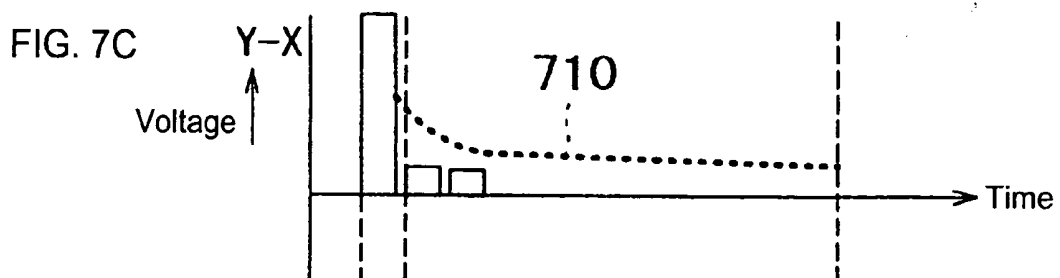
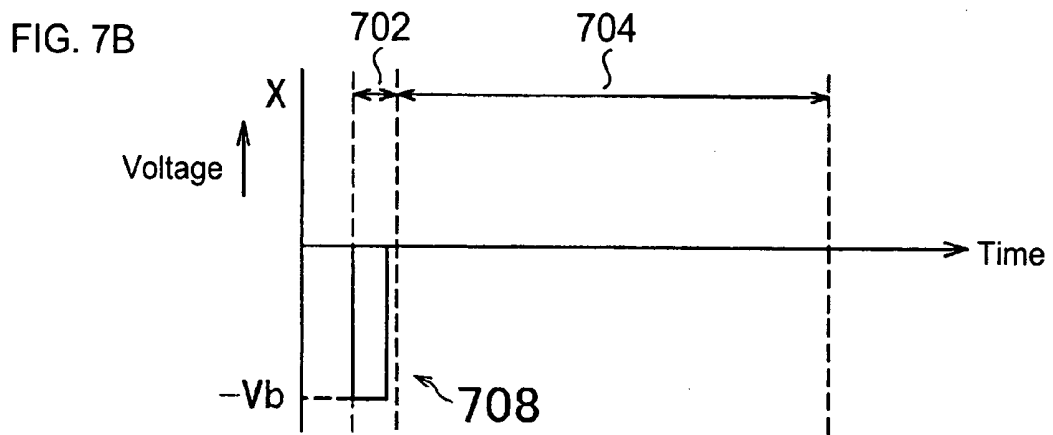
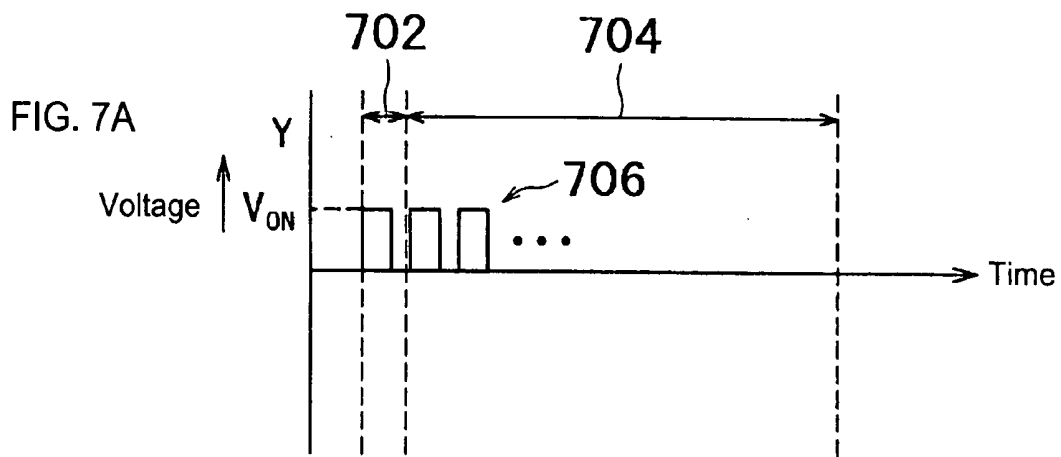
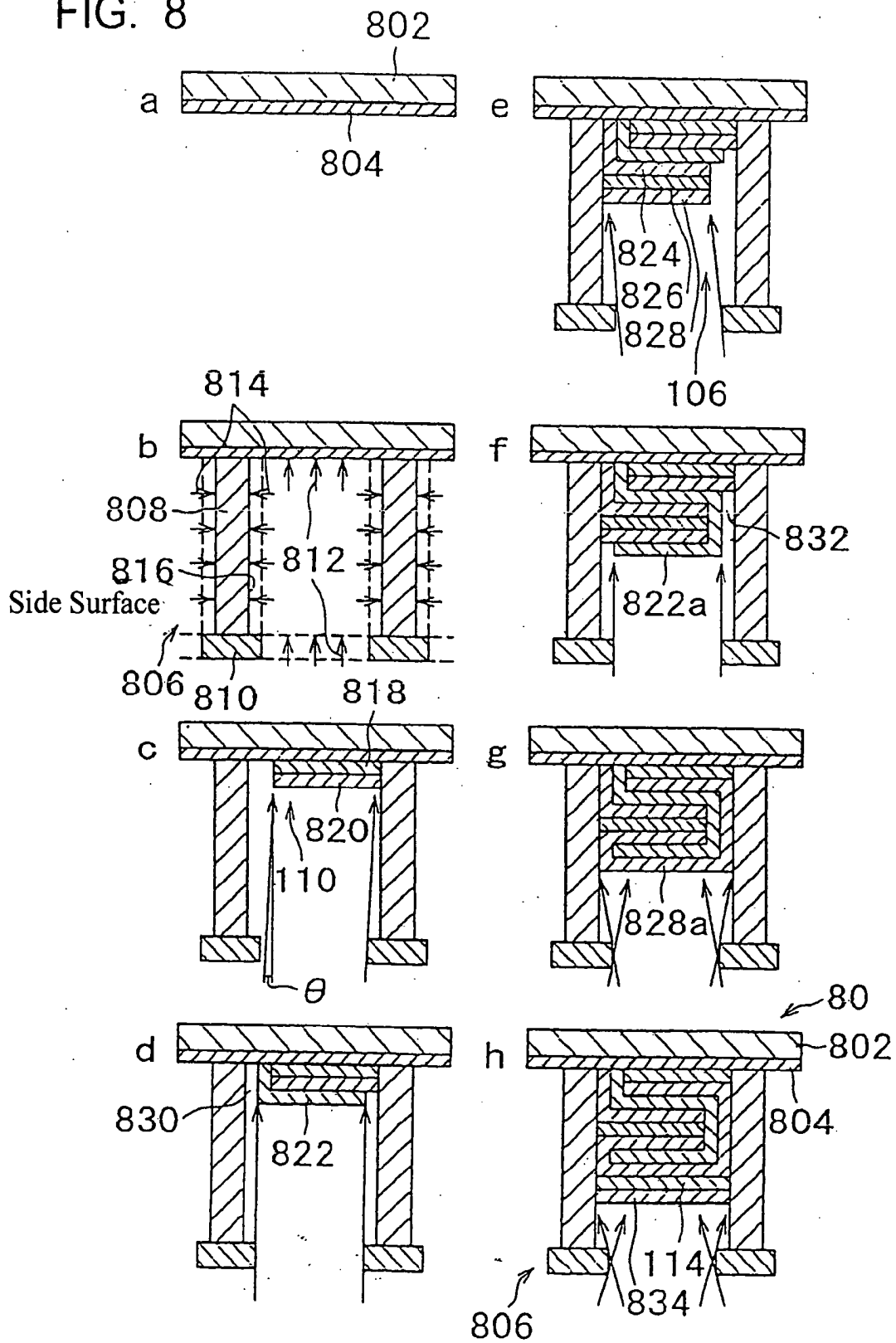

FIG. 8



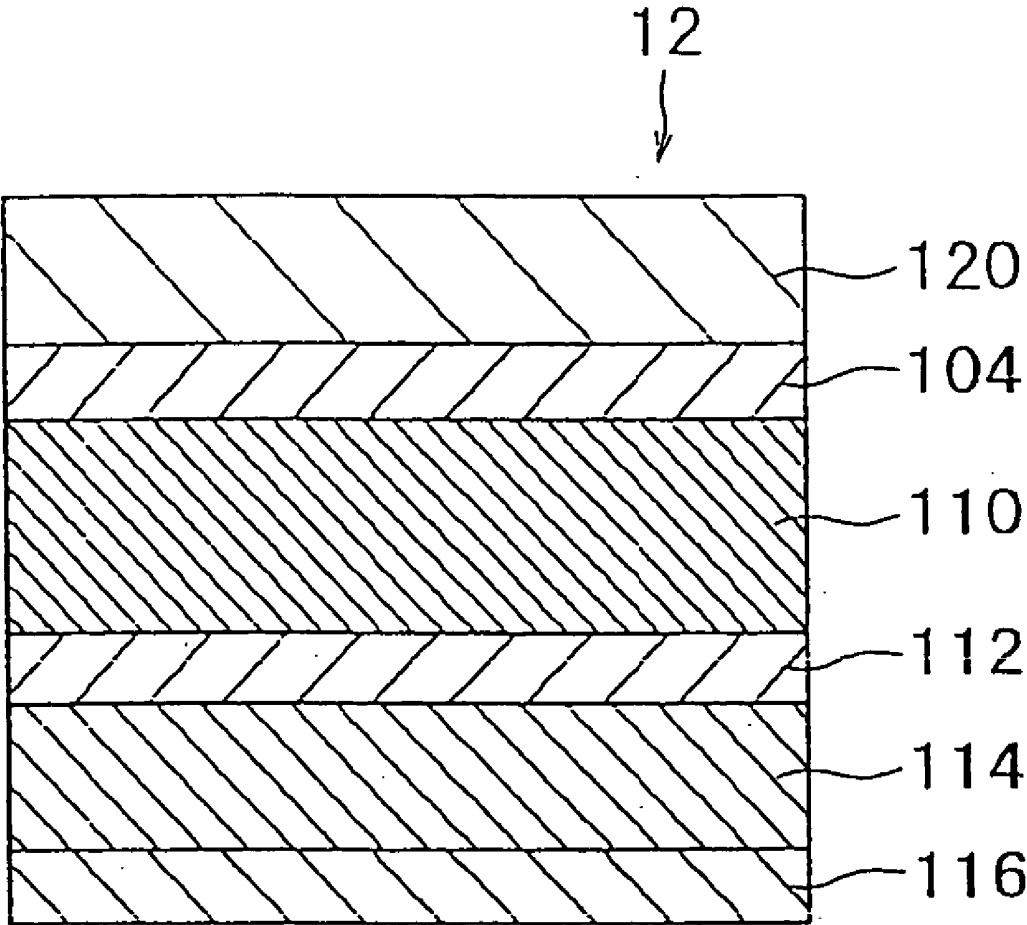

FIG. 9

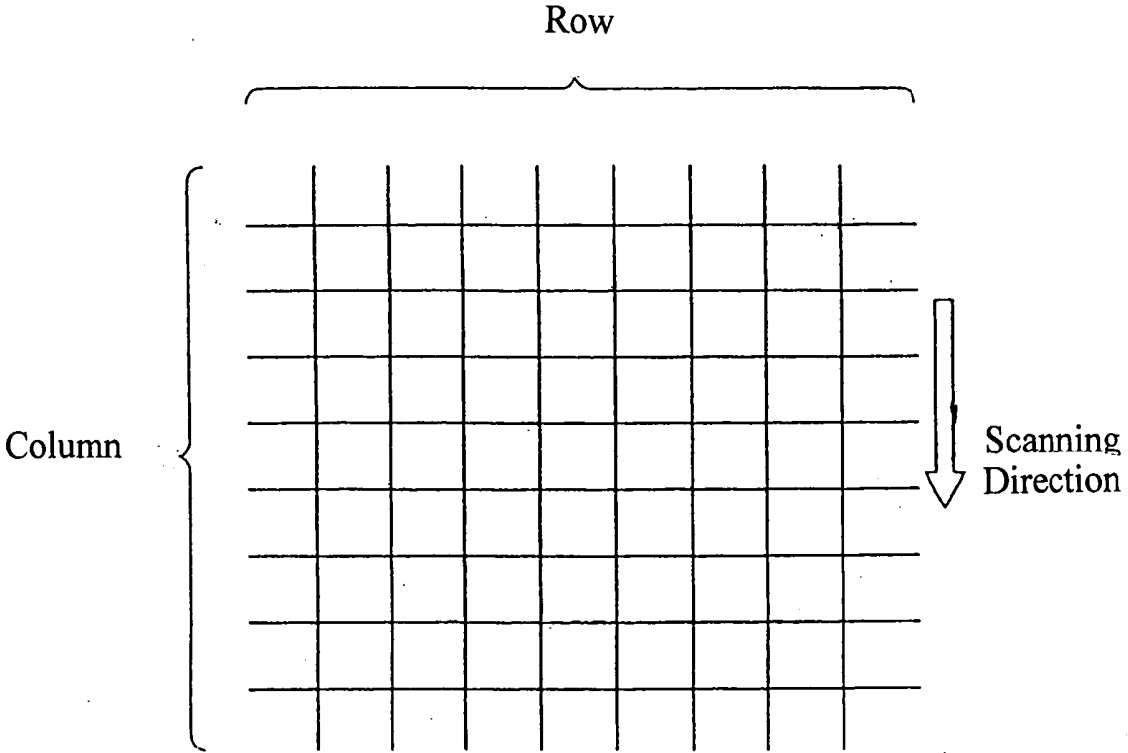

FIG. 10

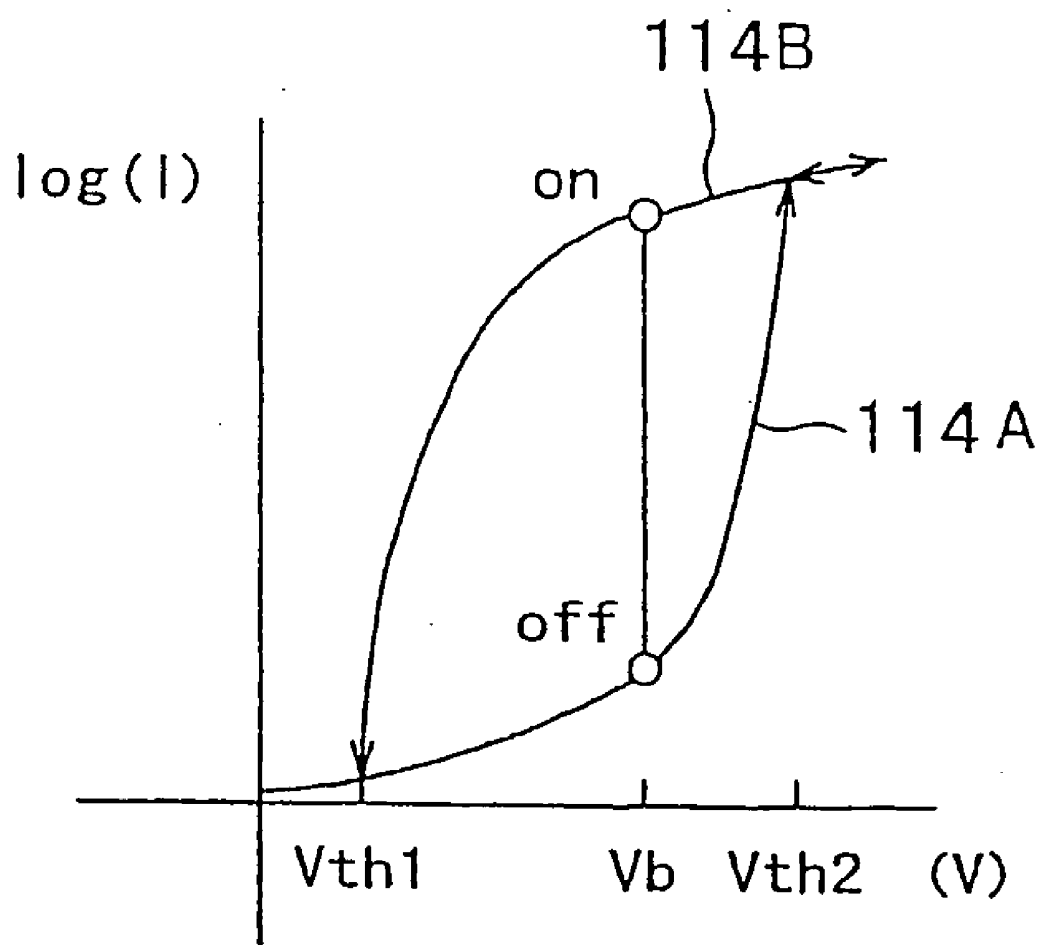

FIG. 11

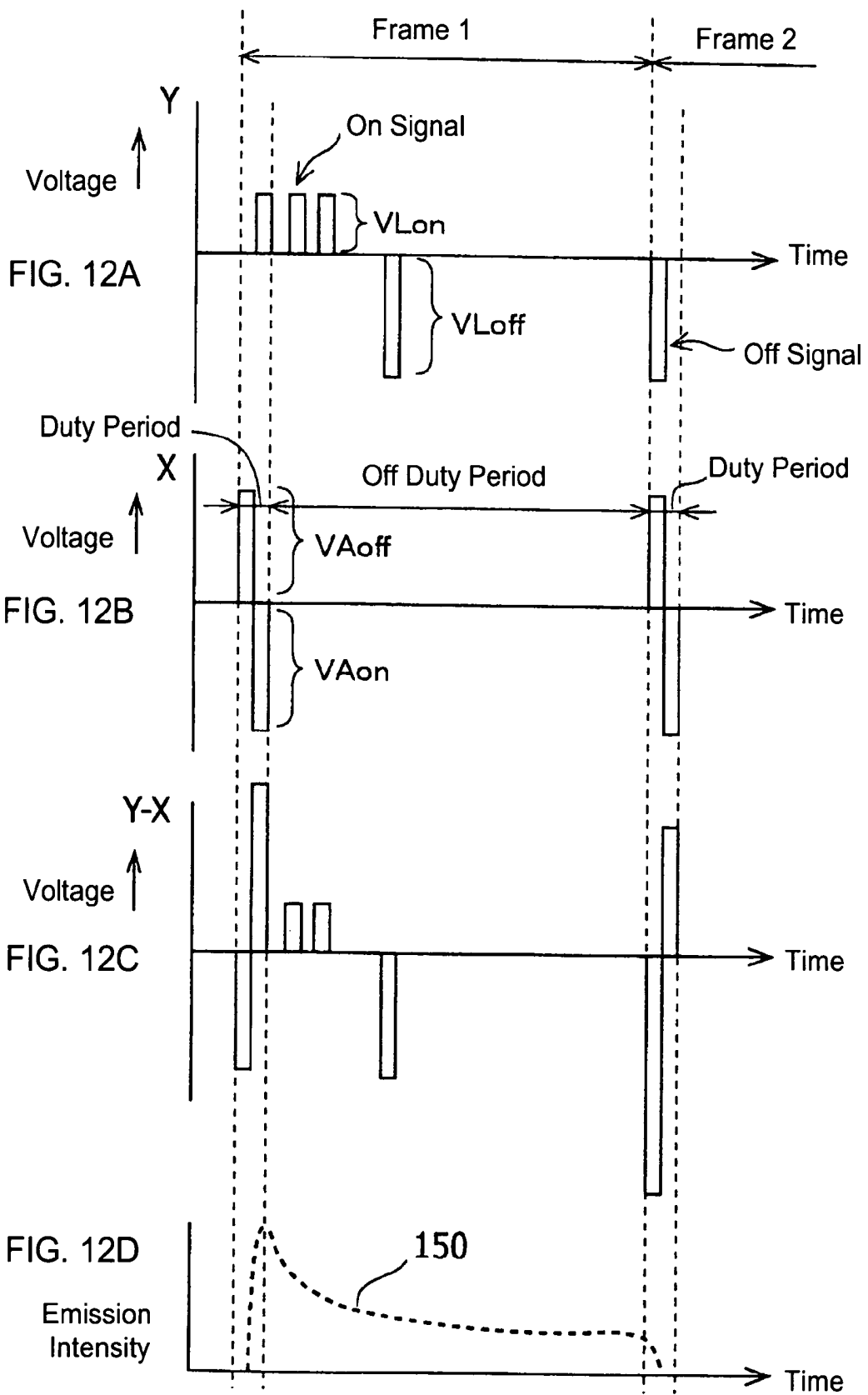

FIG. 13

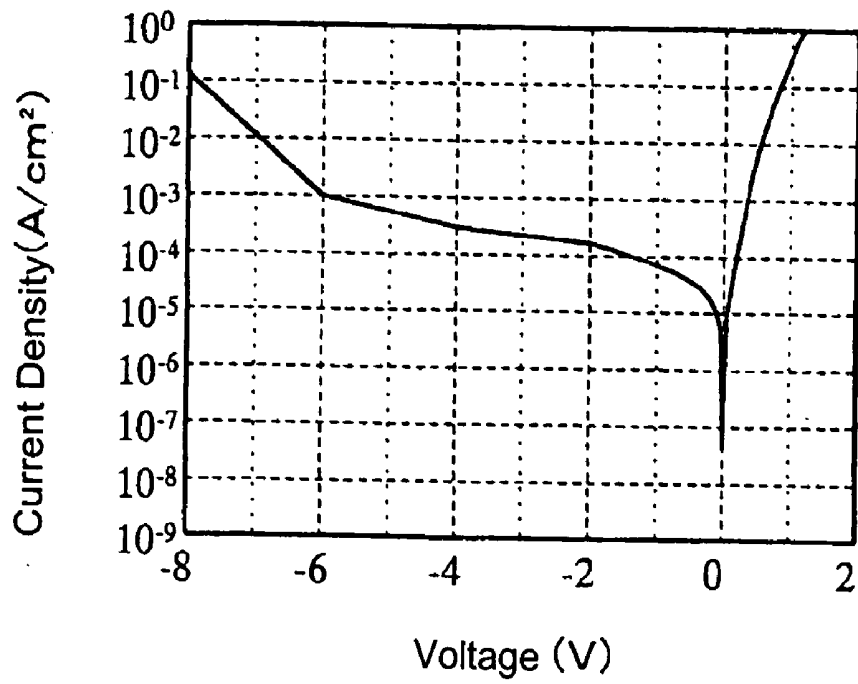

FIG. 14

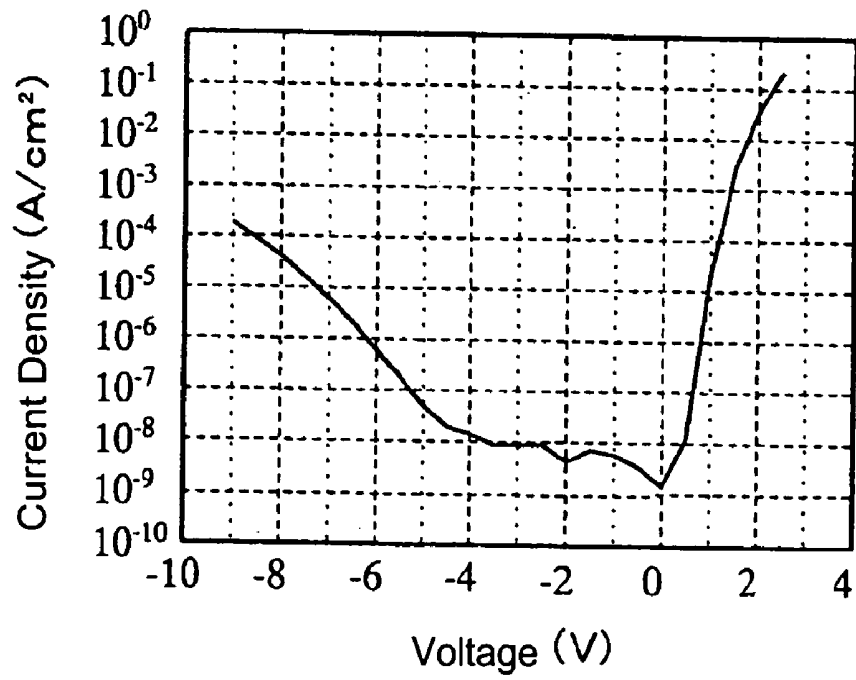

FIG. 15

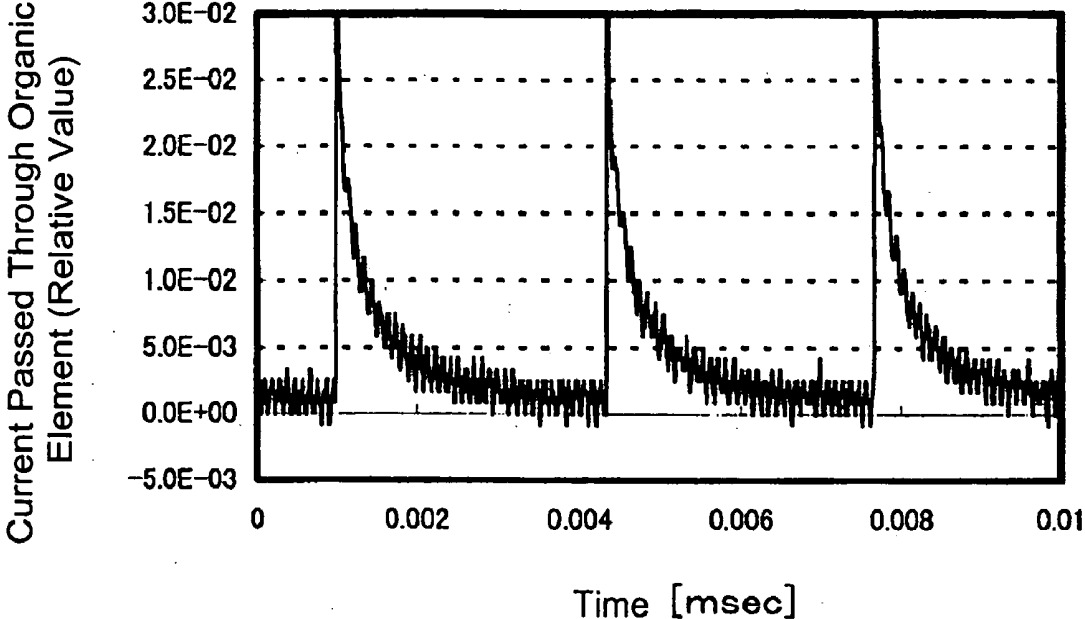

FIG. 16

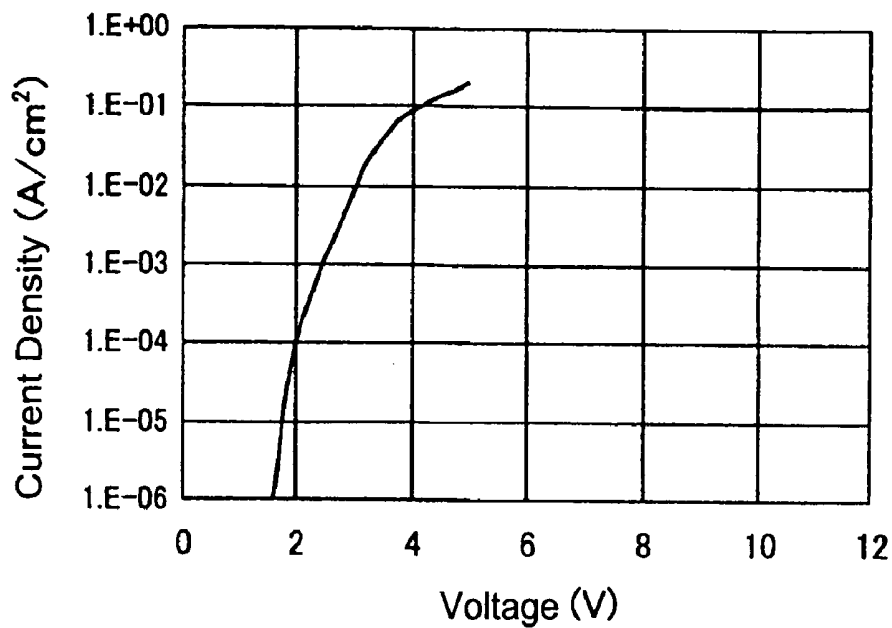
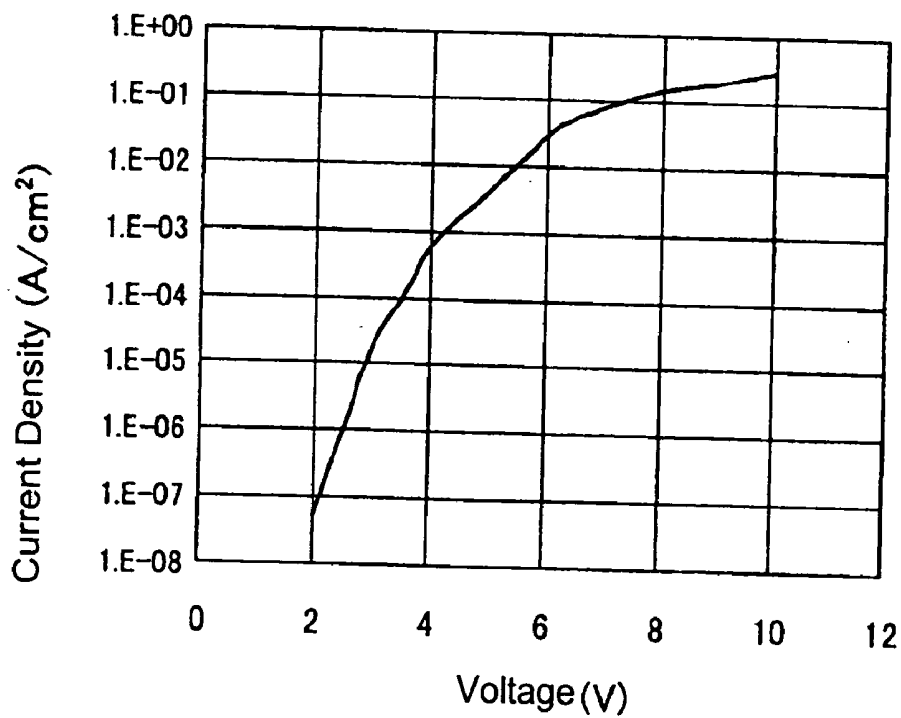
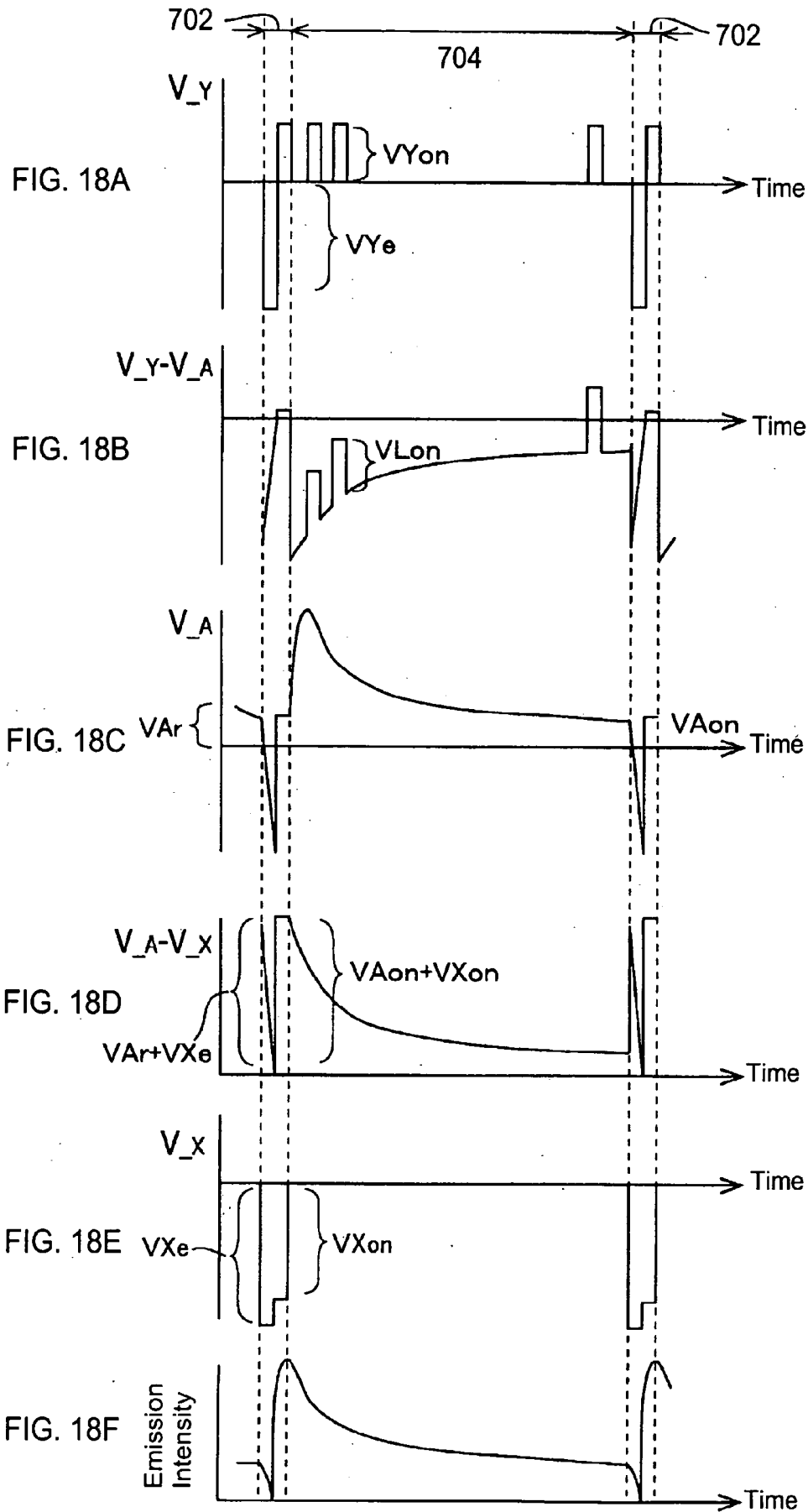
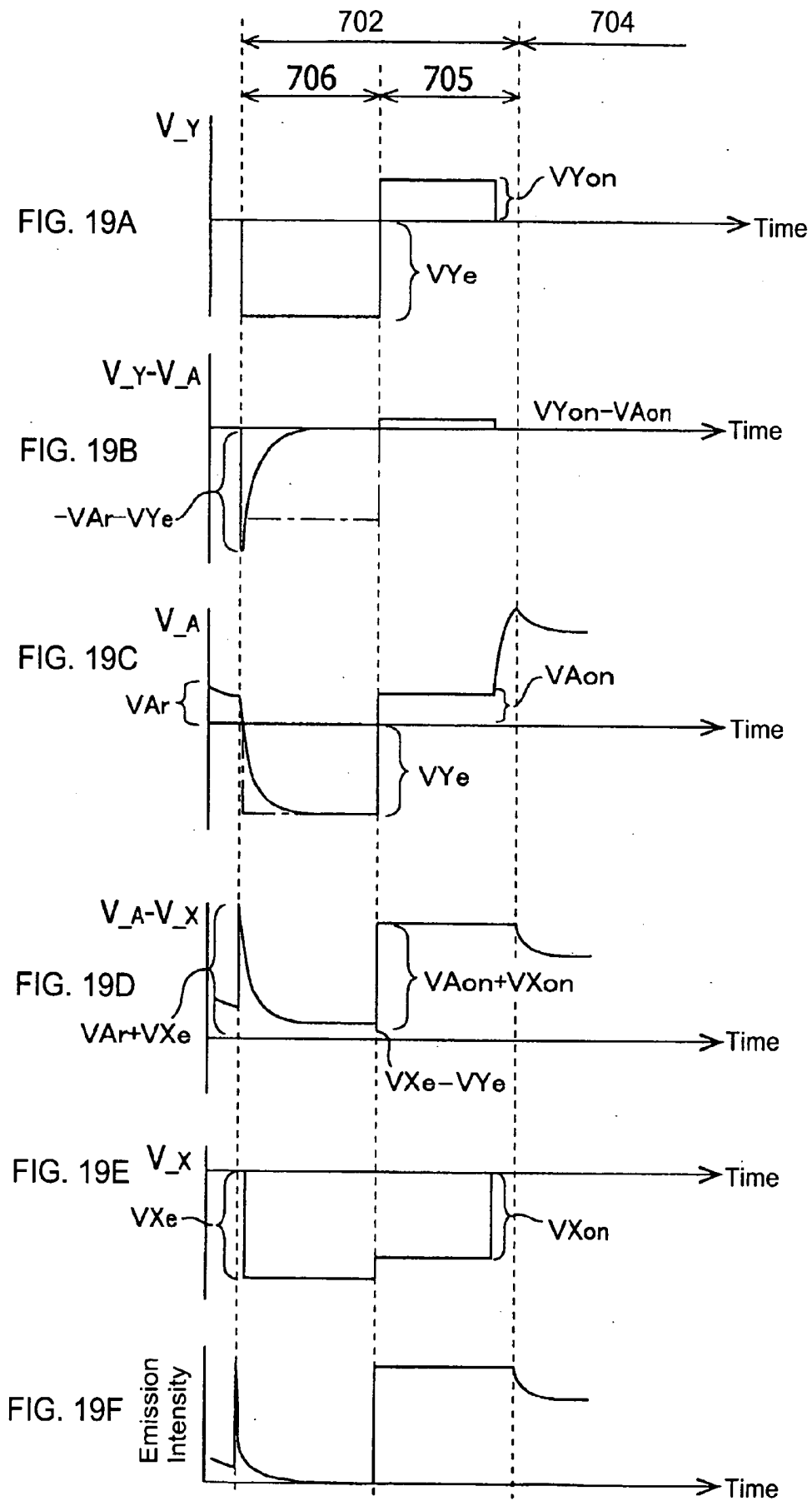

FIG. 17







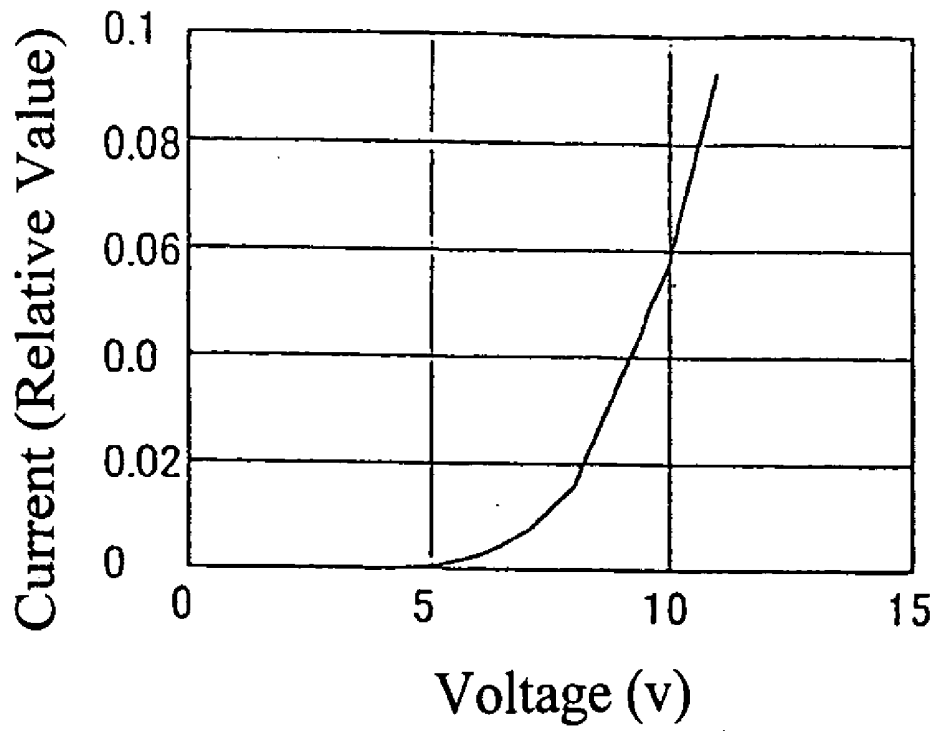

FIG. 20

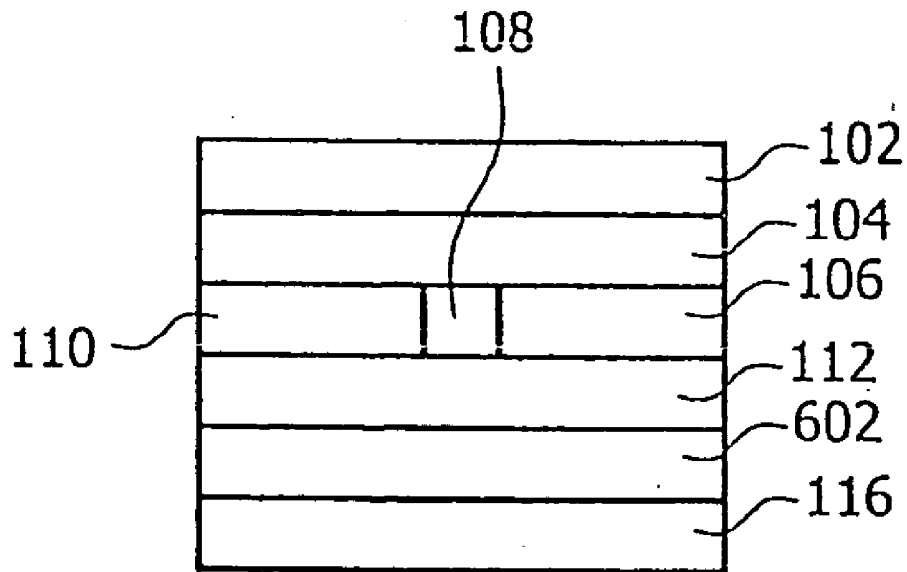

FIG. 21

DISPLAY DEVICE AND METHOD OF FORMING AND DRIVING THE SAME

[0001] This is a National stage application of PCT/JP2004/011603 filed on Aug. 12, 2004, under 35 U.S.C. §371, and claims priority under 35 U.S.C. §365 and §119(a) to Japanese Application Nos. JP PA 2003-294919 filed on Aug. 19, 2003; JP PA 2004-031541 filed on Feb. 9, 2004; JP PA 2004-123650 filed on Apr. 20, 2004; and JP PA 2004-151202 filed on May 21, 2004. The disclosures of the priority application, in their entirety, including the drawings, claims, and the specification thereof, are incorporated herein by reference.

BACKGROUND

[0002] The present invention relates to a self-emission display device of an organic EL (electroluminescence) display panel, and a method for driving the display device. More specifically, the invention relates to a display device comprising emitting pixels having a matrix structure of a plurality of columns and rows, the pixels being driven by a switching element, and relates to a method for producing the same, and a method for driving a display device.

[0003] Reentry liquid crystal displays are remarkably spreading as flat displays of information equipments. The liquid crystal displays utilizes an optical shutter function of a liquid crystal for on/off controlling a light from a backlight, thereby providing colors using color filters. On the contrary, organic EL or LED displays have self-emission pixels, and thereby have many advantages in that, for example, they need no color filters and thus have wide viewing angle, they need no backlights and thus can be made thin, and they can be formed on a flexible substrate. Therefore, the organic EL displays are expected as next-generation displays.

[0004] Drive systems of the organic EL display panels are classified into 2 types. The first is a so-called passive matrix type drive system (or a duty drive system or a simple matrix system). In this system, a plurality of stripe electrodes are combined into a matrix of columns and rows, pixels are formed overlappingly between each of the column electrodes and each of the row electrodes, and a driving signal is applied to the column electrodes and the row electrodes to emit a light. The signal for emission control is generally scanned column by column in the column direction through time, and applied simultaneously to the rows in the same column. In the passive matrix type drive system, each pixel generally has no active elements, and the emission is controlled only in the duty period of each column in the scan period. The second is an active matrix type drive system, which has a switching element in each pixel and can emit light over the column scan period.

[0005] The advantages of the active matrix type drive system are described below. Described as an example is the case of making a panel of 100 columns×150 rows emit light with a display luminance 100 Cd/m². Essentially each pixel always emits light in the active matrix type drive system, where each pixel can be made to emit light at 100 Cd/m² when the pixel area ratio and various losses are ignored. On the contrary, in the case of achieving the same display luminance in the passive matrix type drive system, the duty ratio of driving each pixel is 1/100, and each pixel emits

light only in the duty period (select period), so that the luminance in the period has to be 10,000 Cd/m², 100 times as large as the above.

[0006] Current applied to the organic EL element can be enhanced to increase the luminance. However, it is known that the light-emitting efficiency of the organic EL element is reduced as the current is enhanced. When the active matrix type drive system and the passive matrix type drive system are compared at the same display luminance, the passive matrix type drive system shows a relatively large power consumption due to the reduction of the efficiency. Further, when the current applied to the organic EL element is enhanced, the materials are likely to be deteriorated by heat generation, etc., so that the lifetime of the display device is shortened disadvantageously. When the maximum current is limited in view of the viewpoints of the efficiency and the lifetime, the emission period has to be extended to obtain the same display luminance. However, the duty ratio, which defines the emission period of the passive matrix type drive system, is the reciprocal of the number of columns in the panel, where the extension of the emission period limits the display capacity (number of driving lines). In terms of the problems, the active matrix type drive system is demanded to achieve a large-area, high-definition panel.

[0007] In the active matrix type drive system suitable for the large area and the high definition, a thin film transistor (TFT) using polysilicon is used as the switching element of the pixel. However, the TFT using polysilicon is formed at high temperature of at least 250° C., where it is difficult to use a flexible plastic substrate therefor. Further, the display device using the active matrix type drive system is disadvantageous in high production costs. For example, the production cost of active matrix substrate is 50% or more of the total cost of the display panel.

[0008] To overcome the problems of the conventional organic EL display panels, JP-A-2001-160492 (Patent Document 1) discloses a novel type of organic thin film EL device.

[0009] Described in Patent Document 1 are a novel organic thin film EL device and a method for driving the same, and the device has such a memory property that the emission and non-emission states depend on past applied voltage unlike the conventional devices, so that the states can be controlled by applying on/off signals. More specifically, the content of the disclosure is as follows: a current switching layer comprising a thin film of a substance, which is converted from an insulating material to a conductive material by applying a predetermined amount of voltage, is formed between an organic thin film and one or both electrodes; a predetermined voltage is applied to the electrodes to convert the current switching layer from insulating to conductive, thereby turning the organic thin film electroluminescence device into the emission state; then the voltage is reduced to convert the current switching layer from conductive to insulating, thereby turning the device into the non-emission state; and in a particularly preferred embodiment, the emission and non-emission states is switched by applying a constant voltage to the device continuously and by overlapping positive and negative pulse voltages with the constant voltage.

[0010] Further, WO 01/15233 (Patent Document 2) discloses driving control of a pixel by an organic thin film

transistor. In this disclosure, a driving device is composed of an organic material, where the device can be produced at low temperature and thus a flexible plastic substrate can be used. Additionally inexpensive materials and processes can be used to achieve cost reduction.

[0011] In terms of the switching element, "Formation of Cu:TCNQ Complex Thin Film by Vacuum Deposition and Switching Element," 49th Oyo Butsurigaku Kankei Rengo Koenkai Koen Yokoshu, March 2002, Tokai University, Shonan Campus, Third issue, 27a-M-5 (Non-Patent Document 1) is known as a technology for driving an organic LED. Further, a switching element comprising aminoimidazole dicarbonate (AIDCN) for binary-driving an organic EL element, and possible application thereof for memory, etc., are shown in a paper L. P. Ma, "Organic electrical bistable devices and rewritable memory cells," *Applied Physics Letters*, Vol. 80, number 16, 22 April 2002, 2002 American Institute of Physics (Non-Patent Document 2). These elements have binary resistance to one voltage, and the switching is achieved by applying appropriate pulse. Though the resistance switching takes only about 10 nsec and has response sufficient for common display drive, a specific method of driving a display device with a matrix structure (a dot matrix display) is not disclosed in the documents.

[0012] The display device having a matrix structure is generally driven in the following manner. First, the case of one pixel is described below. As shown in FIG. 11, the exemplified switching element has two volt-ampere characteristics of a high-resistance property 114A (off state) and a low resistance property 114B (on state), and under a bias V_b , an applied voltage of V_{th2} or more causes off to on transition and an applied voltage of V_{th1} or less causes on to off transition. Thus, the resistance can be switched by applying a pulse of V_{th2} or more to cause the off to on transition and by applying a pulse of V_{th1} or less to cause the on to off transition.

[0013] In a display device 12 shown in FIG. 9 having a display pixel with a stack structure, as shown in FIG. 10, columns are sequentially selected to cause scanning display, and data is written in a column of the selected period. The case where a plurality of pixels are arranged into a matrix of thus defined rows and columns to perform dot matrix display is described below. In the display device 12 of FIG. 9, a column electrode 104, a light-emitting portion 110, a pixel electrode 112, a switching element 114, and a row electrode 116 are formed on one surface of a glass substrate 120.

[0014] In such a plurality of pixels with the matrix structure, by controlling a pixel of a column in the above manner and by maintaining bias within the range of V_{th1} to V_{th2} until the scan period, the switching element can be maintained in the state of on or off without limitation of the duty period. This control causes the following disadvantage. In the case of using the above switching element shown in FIG. 9, voltage has to be continuously applied to the switching element in the scan period (the frame period), and thus voltage has to be continuously applied to the pixels in the entire matrix, where also circuits in the columns other than the selected column has to be in the connected states. Thus, a switching signal for one column is applied to all the columns. As a result, in the case of using the switching element 114 shown in FIG. 9, it is difficult to achieve the on/off control of the pixels in the entire matrix by using the conventional passive matrix type drive system per se.

[0015] To solve the above problem, described as a method for driving a matrix-structure display device in a patent application by some of the present inventors (Japanese Patent Application No. 2002-255763) is a method for driving a light-emitting panel, comprising duty-driving columns one-by-one and applying a signal for emission control successively to the corresponding rows in the same column to make pixels emit light by current-driving. In the method, to cause emission or quenching of a particular pixel in response to an emission or quenching signal applied in a predetermined window period, a predetermined voltage is applied to a column to be duty-driven, and an offset voltage of the predetermined voltage is applied to the other columns only in the window period.

[0016] According to the method described in Japanese Patent Application No. 2002-255763, there is provided a display device having a matrix structure. In this method, the emission state of each pixel is on/off binary, and to obtain tone, the duty drive frequency has to be increased to change the emission levels in each period, or alternatively the pixel areas have to be different. However, in these methods, the devices are required to have a high response, and the obtained tone level is insufficient because of the influence on image resolution. For example, 8 tones can be controlled by increasing the duty drive frequency from common 60 Hz to 480 Hz. However, 256 tones are required in each of 3 colors to obtain a so-called full color (16,770,000 colors). It is difficult to obtain more drive frequency than this from the viewpoint of the response of the device, where full color display cannot be obtained by increasing the frequency of the passive matrix type device.

[0017] The full color display can be obtained using a conventional silicon TFT, etc. However, as described above, preparation of the silicon TFT on a flexible plastic substrate is difficult and costly.

[0018] Accordingly, there is a need to provide a display device such as an organic EL display panel, which can show multiple tones at a low cost and can be formed on a flexible substrate, and a method for driving the same, in view of the above problem.

[0019] Further, from the viewpoint that efficiency and lifetime of an organic EL element are reduced as the emission luminance is increased, there also is a need to provide a display device, which comprises a thin film light-emitting element comprising a capacitor connected to an organic EL element in parallel and has excellent display properties with sufficient areas of the light-emitting element and the capacitor, and a method for producing the same.

[0020] As shown in FIGS. 3(a)-3(c), organic EL elements generally have remarkably high electrical resistance at low voltage, so that discharge of capacitor becomes slow at a certain voltage. Thus, as shown in FIG. 15, the charge remains in the capacitor even in the next duty period, and affects the light emission in the next frame period. To prevent the affect, the residual charge in the capacitor has to be removed once. The on/off ratio is reduced particularly in a case where a light remains in a non-emission frame. As a measure against this problem, for example, JP-A-2001-350431 discloses a method of connecting a capacitor portion and a light-emitting portion to different wirings, and applying a reverse bias voltage to the capacitor portion to eliminate the residual charge in the non-emission state. Further,

JP-A-2003-228326 discloses a similar method. These methods can eliminate the previous record. However, the eliminated electric power does not contribute to light emission and is ineffective, to cause the power consumption increase. Further, not every accumulated charge contributes to emission, and this causes a problem of unevenness of light emission. Furthermore, more wirings for the pixels are required to increase the production costs.

SUMMARY OF THE INVENTION

[0021] One aspect of the present invention is a display device. The display device can comprise a substrate, first stripe electrodes formed in parallel with each other on the substrate, second stripe electrodes formed in parallel with each other, crosswise to the first stripe electrodes on the substrate, and a plurality of pixels formed overlappingly between each of the first stripe electrodes and each of the second stripe electrodes. Each of the pixels can comprise a switching element comprising a two-terminal nonlinear element connected electrically to one of the first stripe electrodes, a light-emitting portion connected electrically to the switching element and one of the second stripe electrodes, and a capacitor portion comprising an organic dielectric material or ceramics material as a dielectric layer, connected electrically to the switching element and the one of the second stripe electrodes in parallel with the light-emitting portion.

[0022] By using the two-terminal nonlinear element as the switching element in a drive system similar to a passive matrix drive system (or a duty drive system, or a simple matrix drive system), a hold type display (display not only in the duty period but also in the off duty period) can be obtained by the switching element. The capacitor portion acts to accumulate charge for light emission in the off duty period. The hold type display can be achieved in the two-terminal element by using the capacitor portion.

[0023] When the organic dielectric material is used for the dielectric layer, the layer does not have to be formed at high temperature and can respond to deformation of the substrate.

[0024] When the ceramics material is used for the dielectric layer of the capacitor portion, the ceramics material can comprise barium strontium titanate oxide.

[0025] When using the organic dielectric material for the dielectric layer, it is preferable for the dielectric layer to further comprise a large number of conductive fine particles dispersed. The switching element is preferably a bistable element or a diode element. When dispersing metal micro-particles, the practical relative dielectric constant is 50 to 150 though it depends on deposition conditions. When using the organic dielectric material, the relative dielectric constant is preferably 50 or more, more preferably 100 or more.

[0026] When using barium strontium titanate oxide for the dielectric layer, the relative dielectric constant is approximately 250 to 800. Further, barium strontium titanate oxide has a high resist voltage of about 50 MV/m, at most 150 MV/m. When using a ceramics-based material, the relative dielectric constant of the material is preferably 250 or more. Further, the ceramics-based material preferably has a resist voltage of 50 MV/m.

[0027] The switching element preferably has a stack structure of aluminum/dicyano compound/aluminum, a film stack

of a polyethylene dioxythiophene film and a polyphenylenevinylene film, a stack structure of an aluminum thin film/a fullerene thin film/a copper thin film, or a stack structure of an aluminum electrode/a butadiene compound/a gold electrode.

[0028] The diode preferably comprises C60 or pentacene.

[0029] By using the conductive fine particles, the effective dielectric constant of the dielectric layer is increased, and thereby the capacitor portion can have a sufficient capacity in a small area. Thus, the area of the light-emitting portion can be increased, where the current density in the light-emitting portion can be reduced to improve the light-emitting efficiency and lifetime of the portion. Further, when the bistable element is used in the display device of the invention, the bistable element acts in combination with the capacitor portion to maintain the emission in the off duty period, so that the display with a larger capacity (a larger number of display lines) can be obtained in addition to excellent light-emitting efficiency or lifetime. Also in the case of using the diode element, the capacitor portion can be sufficiently charged when the diode element is in the conducting state, so that the display with a larger capacity can be obtained in addition to excellent light-emitting efficiency or lifetime. Further, when using C60 or pentacene in the diode, the voltage drop is smaller as compared with the case of using the other organic material. Thus, the power loss is prevented, and the diode is remarkably advantageous in the power consumption.

[0030] It is preferable for the display device to comprise the light-emitting portion and the capacitor portion in the same plane, or further comprises an insulation portion for electrically separating the light-emitting portion from the dielectric material layer of the capacitor portion. When the light-emitting portion and the capacitor portion are disposed in the same plane, the display device with a simple structure can be produced.

[0031] It is also preferable for the substrate to be a flexible substrate. The display device can be produced without high-temperature processes, where the flexible substrate can be used. A display device having lighter weight and higher impact resistance can be obtained by using the flexible substrate, as compared with the case of using a glass substrate.

[0032] It is also preferable for the display device to be such that the light-emitting portion, the capacitor portion, and the switching element are thin films formed on the substrate, have electrode layers on both sides, and are stacked on the substrate in this order or the reverse order together with the electrode layers, the capacitor-facing electrode of the light-emitting portion and the capacitor-facing electrode of the switching element are electrically connected by a first via in the capacitor portion, the light-emitting portion-facing electrode of the capacitor portion and the one of the second stripe electrodes are electrically connected by a second via in the light-emitting portion, and the display device further comprises an insulation portion for insulating the light-emitting portion from the capacitor portion.

[0033] The via is also referred to as a through hole, and known to those skilled in the art as a measure for electrically connecting layers. When using the stack structure of the light-emitting portion and the capacitor portion, the light-

emitting portion and the capacitor portion can have large areas, and thus can have excellent efficiency, lifetime, and capacity.

[0034] It is preferable for the first via to be formed along a side of the capacitor portion through a side surface of the capacitor portion and lined with an insulating material, the second via to be formed along a side of the light-emitting portion through a side surface of the light-emitting portion and lined with an insulating material, and the insulating materials to be continuous with the insulation portion.

[0035] When stacking the capacitor portion and the light-emitting portion, the vias for maintaining the electric connection can be disposed through the side surfaces of the capacitor portion and the light-emitting portion to simplify the structure of the vias. The vias can be lined with the insulating material continuous with the insulation portion. Thus, the display device can have a simpler structure.

[0036] It is preferable for the display device to comprise an electrode layer as the first or second stripe electrodes on the substrate, and to further comprise a plurality of electrically insulating barriers, which extend crosswise to the stripe electrodes of the electrode layer, divide adjacent pixels in the direction of the stripe electrodes, and have an overhang portion protruding in parallel with the substrate at the top.

[0037] Another aspect of the present invention is method for producing the display device described above. The method can comprise the steps of forming the light-emitting portion having the electrode layers by oblique deposition using the barrier as a mask, forming the insulation portion by oblique deposition using the barrier as a mask, forming the capacitor portion having the electrode layers by oblique deposition using the barrier as a mask, and forming the switching element having the electrode layers by oblique deposition using the barrier as a mask.

[0038] By using the overhang portion, the display device can be produced without costly photo processes. Such a display device with excellent display properties can be produced while maximally eliminating mask deposition processes, which is a process for forming a film through a mask.

[0039] Another aspect of the present invention is a method of driving the display device, which is a dot matrix display, using a duty drive system that addresses each of the pixels by column electrodes and row electrodes of the combination of the first and second stripe electrodes. The method can comprise a first step of applying a signal for converting the switching element to a conducting state by the column electrode, the row electrode, or both thereof during a duty period of a selected column, a second step of accumulating a charge for light emission of the light-emitting portion in the capacitor portion through the conducting-state switching element by the column electrode, the row electrode, or both thereof during the duty period of the selected column, and a third step of applying a signal for converting the switching element to a non-conducting state by the column electrode, the row electrode, or both thereof during the duty period of the selected column. The method further includes the step of releasing the charge accumulated in the capacitor portion from the light-emitting portion to emit a light therefrom during an off duty period of the selected column.

[0040] The driving method can use a dot matrix drive, which uses the pixels for displaying an image, each pixel being addressed by the columns and rows (or X and Y). The signal for converting the two-terminal nonlinear element into the conducting state can be used for the two-terminal nonlinear element having no hysteresis property or for the element having a hysteresis property (e.g. the bistable element), and is generally a high voltage. When the charge is then accumulated, a signal is applied such that a current sufficient for accumulating the charge is provided depending on the properties of the two-terminal nonlinear element.

[0041] The charge for making the light-emitting portion emit a light is selected in view of achieving a desired emission luminance, and multiple tones can be displayed in accordance with the amount of the charge.

[0042] Further, when the switching element is converted to the non-conducting state, the signal is such that the leak current, leaked through the switching element, is practically in the non-conducting state. The signal is applied by the column electrodes and the row electrodes to the switching element, and the light-emitting portion and the capacitor portion, which are connected in series with the switching element and connected in parallel with each other. It is preferable for the signal to cause the switching action of the switching element appropriately. The signal for converting to the non-conducting state is particularly effective in the case of using the bistable element.

[0043] The first and second steps can be carried out in a predetermined first window period and a predetermined second window period, respectively. The first and second window periods are time intervals determined in this order between the duty periods of the selected columns.

[0044] It is preferable for, in the first step, a voltage offset signal to be applied to the column electrodes of columns other than the selected column, the voltage offset signal having a polarity equal to that of a voltage signal applied to the row electrode. Further, it is also preferable for, in the first step, the voltage offset signal to be applied to the column electrode of the selected column, the voltage offset signal having a polarity reverse to that of the voltage signal applied to the row electrode. In addition, it is also preferable for, in the third step, the voltage offset signal to be applied to the column electrodes of columns other than the selected column, the voltage offset signal having a polarity equal to that of the voltage signal applied to the row electrode. Furthermore, it is also preferable for, in the third step, the voltage offset signal to be applied to the column electrodes of columns other than the selected column, the voltage offset signal having a polarity equal to that of the voltage signal applied to the row electrode.

[0045] In the first or third steps in the duty period of the selected column, when the offset signal having the equal polarity is applied to the column electrodes of the unselected columns (the columns other than the selected column) such that the voltage signal (the voltage pulse, etc.) applied to the row electrode is cancelled, the switching element can be converted into the conducting state or the non-conducting state only in the selected column. Further, when the offset signal having the reverse polarity is applied to the column electrode of the selected column such that the offset signal is added to the voltage signal (the voltage pulse, etc.) applied to the row electrode, the offset voltage is applied overlap-

ping the voltage of the row electrode, where the switching element can be converted into the conducting state or the non-conducting state only in the selected column in the same manner as above.

[0046] To convert the switching element into the conducting state or non-conducting state, considering the properties of the switching element and the voltage share of elements connected therewith in series, a voltage signal of more than the threshold value of converting the switching element into the conducting state or less than the threshold value of converting the switching element into the non-conducting state is applied by the column electrode of the selected column and the row electrode. The offset voltage applied to the column electrodes of the unselected columns is determined such that it is not more (or less) than the threshold value.

[0047] Another aspect of the present invention is a method of driving a dot matrix display device using a duty drive system that addresses each of the pixels by column electrodes and row electrodes of the combination of the first and second stripe electrodes. Here, the method can comprise a first step of converting the switching element into the conducting state and accumulating a charge for light emission of the light-emitting portion through the conducting-state switching element in the capacitor portion by the column electrode and the row electrode during a duty period of a selected column. The method further comprises the step of releasing the charge accumulated in the capacitor portion from the light-emitting portion to emit a light therefrom during an off duty period of the selected column.

[0048] Another aspect of the present invention is a method of driving the dot matrix display device. Here, the method comprises a first step of applying a reverse bias voltage to the switching element, accumulating a charge through the switching element in the capacitor portion, and applying a signal for making the charge releasable by the column electrode, the row electrode, or both thereof during a duty period of a selected column in a frame period, and a second step of applying a forward bias voltage to the switching element to convert the switching element to a conducting state, thereby accumulating a charge for emission of the light-emitting portion in the capacitor portion through the conducting-state switching element by the column electrode, the row electrode, or both thereof during the duty period of the selected column in the frame period. The method further comprise the step of releasing the charge accumulated in the capacitor portion from the light-emitting portion to emit a light therefrom during an off duty period of the selected column in the frame period. Further, the first step releases the residual charge remaining in the capacitor portion corresponding to the selected column during the duty period of the selected column in the next frame period.

[0049] When the switching element is a diode element that shows a low resistance at high voltage and shows a high resistance at low voltage, the capacitor can be charged through the diode element when a high voltage is applied to the switching element, and matrix driving can be conducted without leakage of the charge through the diode element when the voltage is lowered.

[0050] Further, in the duty period, the charge accumulated in the previous frame can be certainly released by using the reverse bias for releasing the charge in the capacitor.

[0051] An example of a method for using a rectifier for pixel emission control in the dot matrix display device is described below. The dot matrix display that uses the duty drive system that addresses each pixel by stripe electrodes of row electrodes (data signal lines or Y electrodes) 116 and column electrodes (timing signal lines or X electrodes) 104, such as shown in FIG. 6. The method comprises a first step of converting the rectifier into the conducting state by the column electrodes, the row electrodes, or both thereof, to accumulate a charge in the capacitor portion during a duty period of a selected column, and a second step of applying a signal for converting the rectifier to the non-conducting state by the column electrode, the row electrode, or both thereof during the duty period of the selected column. The method further comprises a third step of maintaining current in the light-emitting portion by the charge accumulated in the capacitor portion during an off duty period of the selected column. Further, the method comprises a fourth step of converting the light-emitting portion to the conducting state by the column electrodes, the row electrodes, or both thereof, to release the charge remaining in the capacitor portion during the next duty period of the selected column, and a fifth step of applying a signal for converting the light-emitting portion to the non-conducting state by the column electrodes, the row electrodes, or both thereof during the next duty period of the selected column.

[0052] When the charge is accumulated through the rectifier in the capacitor portion, a signal capable of applying current sufficient for accumulating the charge is applied depending on the properties of the rectifier. Further, the charge can be such that the desired emission luminance is obtained, to achieve multiple-tone display depending on the charge amount.

[0053] Further, it is preferable for, when converting to the non-conducting state, the signal to be such that the leak current is reduced to practically non-conducting state.

[0054] The fourth and fifth steps can be carried out in a predetermined first window period (e.g., 706), and the first and second steps can be carried out in a predetermined second window period (e.g., 705). The first and second window periods are time intervals determined in this order between the duty periods of the selected columns. In the fourth and fifth steps, the previous record is eliminated by releasing the remaining charge, and in the first and second steps the next signal is written, so that it is preferable for the steps to be carried out in the above order.

[0055] When the rectifier shows a low resistance at high voltage and shows a high resistance at low voltage, the capacitor can be charged through the rectifier when a high voltage is applied to the rectifier, and matrix driving can be conducted without leakage of the charge through the rectifier when the voltage is lowered.

[0056] Another aspect of the present invention is a method for driving a display device comprising a first electrode, a second electrode, a rectifier connected electrically to the first electrode, a light-emitting portion connected electrically to the rectifier and the second electrode, and a capacitor portion connected electrically to the rectifier and the second electrode in parallel electrically with the light-emitting portion. The method comprises a first step of applying a voltage offset signal to one or both of the first and second electrodes to release a charge remaining in the capacitor portion from

the light-emitting portion during a duty period, and a second step of accumulating a charge for emission of the light-emitting portion in the capacitor portion during the duty period. The method further comprises the step of releasing the charge accumulated in the capacitor portion from the light-emitting portion to emit light therefrom during an off duty period.

[0057] By releasing the charge remaining in the capacitor, accumulated by the previous drive, in the first step during the duty period, the non-emission display is not affected by the emission in the previous drive effectively.

[0058] Further, it is preferable for the first electrode to be one of first stripe electrodes formed in parallel with each other, the second electrode to be one of second stripe electrodes formed in parallel with each other, crosswise to the first stripe electrodes, the display device to comprise a substrate, a plurality of pixels formed overlappingly between each of the first stripe electrodes and each of the second stripe electrodes on the substrate, the rectifier connected electrically to one of the first stripe electrodes and disposed in each of the pixels, the light-emitting portion connected electrically to the rectifier and one of the second stripe electrodes and disposed in each of the pixels, the capacitor portion connected electrically to the rectifier and the one of the second stripe electrodes in parallel with the light-emitting portion, and disposed in each of the pixels, and the display device to be a dot matrix display device that uses the duty drive system previously mentioned. Thus, the dot matrix display can be achieved by using a large number of stripe electrodes.

[0059] The switching element, the light-emitting element, and the capacitor can each comprise an organic electronic material thin film with a thickness of about 100 nm and a metal electrode film. Thus, it is easy to reduce the cost of the display device, increasing the area thereof, and use a flexible substrate therein. Further, multiple tone display can be achieved with low cost. When the display device comprises a thin film light-emitting element comprising a capacitor connected with an organic EL element in parallel, the limitation to the areas of the light-emitting element and the capacitor can be minimized.

[0060] Further, in the preferred embodiments using a large number of conductive fine particles dispersed or barium strontium titanate oxide with a high relative dielectric constant in the dielectric layer of the capacitor portion, the capacitor portion has a high dielectric constant and can accumulate a large amount of charge in a small area, and in the case of apposing the light-emitting portion and the capacitor portion physically, the light-emitting portion can have a larger area to reduce the current density, thereby showing a high light-emitting efficiency.

BRIEF DESCRIPTION OF THE DRAWINGS

[0061] FIG. 1 is an explanatory view showing an example of structure of the display device according to the present invention.

[0062] FIG. 2 is an explanatory view illustrating an equivalent circuit of a display device using a bistable element as a switching element.

[0063] FIGS. 3(a)-3(c) are explanatory views showing an example of voltage and emission state of the display device using the bistable element as the switching element.

[0064] FIG. 4 is an explanatory view showing voltage distribution of an organic EL element and a bistable element connected in series under a voltage.

[0065] FIGS. 5(a) and 5(b) are explanatory views showing an example of a method for applying a voltage to each display device in the duty period and off duty period.

[0066] FIG. 6 is an explanatory view showing an equivalent circuit using a rectifier as a switching element.

[0067] FIGS. 7(a)-7(c) are explanatory views showing an example of voltage and emission state of a display device using the rectifier as the switching element.

[0068] FIGS. 8(a)-(h) are explanatory views showing structure of one embodiment of a display device and a method of producing the same according to the present invention.

[0069] FIG. 9 is a cross-sectional view showing an example of connecting (stacking) a conventional organic EL element and a switching element in series.

[0070] FIG. 10 is an explanatory view showing a matrix structure of a display device.

[0071] FIG. 11 is a view showing volt-ampere characteristic of a switching element under a positive off signal voltage.

[0072] FIGS. 12(a)-12(d) are explanatory views showing an example of voltage and emission state of the display device using a rectifier as a switching element, other than that of FIGS. 7(a)-7(c).

[0073] FIG. 13 is a view showing an example of volt-ampere characteristic of a diode element using C60 as an organic electronic material.

[0074] FIG. 14 is a view showing an example of volt-ampere characteristic of a diode element using pentacene as an organic electronic material.

[0075] FIG. 15 is a view showing time variation of a current applied to an organic EL element according to an embodiment of the present invention.

[0076] FIG. 16 is a view showing an example of volt-ampere characteristic of a diode element using a polyethylene dioxythiophene film and a polyphenylenevinylene film as organic electronic materials.

[0077] FIG. 17 is a view showing an example of volt-ampere characteristic of the organic EL element of Example 2.

[0078] FIGS. 18(a)-8(f) are characteristic views showing time variation of voltage waveform applied to each electrode, voltage waveform applied to each electrode or element, and emission intensity according to an embodiment of the present invention.

[0079] FIGS. 19(a)-19(f) are enlarged characteristic views showing part of the time variation of the voltage waveforms and the emission intensity.

[0080] FIG. 20 is an explanatory view showing an example of electric properties of the light-emitting element of the present invention.

[0081] FIG. 21 is a cross-sectional view showing structure of a pixel of the display device according to an embodiment of the present invention.

DETAILED DESCRIPTION

[0082] Embodiment 1 is described in detail below. In Embodiment 1, in a duty period, a charge corresponding to emission amount is accumulated in a capacitor connected in parallel to a pixel of a column, which is duty-driven, in a matrix. In periods other than the duty period, light is continuously emitted by discharge from the capacitor.

[0083] Although conventionally ceramic oxide-based materials have widely been used as dielectric materials for capacitors, these materials are disadvantageous in that they cannot respond to deformation of substrates. In this embodiment, a dielectric material layer is composed of an organic dielectric material comprising conductive fine particles dispersed to overcome the disadvantage of the conventional capacitors. Further, in this embodiment, a switching element (a bistable element) is in the conducting state after the applied voltage becomes more than the first threshold value and in the non-conducting state after the applied voltage becomes less than the second threshold value, or a rectifier (a diode element). Current is passed through these elements in the vertical direction of the thin film surface, where the elements can be easily stacked with a light-emitting element. And the elements can have a larger current path area, as compared with elements where current is passed in the plane direction, where large current can be easily obtained. Particularly, the electrical resistance of the bistable element can be changed within the range of several figures by applying a pulse electric field. The bistable element is a preferred switching element because it can be controlled and matched to the light-emitting element easily, have a large current effective area to obtain large current, and have a large transition rate.

[0084] Through the switching element, in the duty period, the charge is accumulated in the capacitor connected in parallel with each light-emitting portion in each column. In the off duty period, each pixel is electrically isolated from signal lines (e.g., row electrodes) by the switching element, and a light is continuously emitted by the charge accumulated in the capacitor. The amount of the charge accumulated can be controlled depending on the desired emission intensity, so that the multiple tones can be easily displayed.

[0085] A ceramic oxide-based material is preferably used in the capacitor. For example, an excellent capacitor can be obtained by forming a typical ferroelectric material of barium strontium titanate into a several hundred nanometer-thick film using an RF magnetron sputtering method, and by heat-treating the film at approximately 650° C. As described in JP-A-2002-280380, for example, it is known that a high dielectric constant, e.g., a relative dielectric constant of more than 40, can be obtained even in the case of forming barium strontium titanate into a film at low temperature by plasma anneal.

[0086] FIG. 1 is a cross-sectional view showing the cross section structure of a pixel of a display device 10 according to this embodiment. A column electrode 104 comprising ITO (indium tin oxide) of a transparent electrode material is formed on one surface of a plastic substrate 102. The column electrode 104 can be referred to as a timing signal line, an

X electrode (see FIG. 2). The column electrode 104 is patterned into striped electrodes in parallel with each other. In this figure, one pixel is magnified and the entire patterned electrode is not shown. A light-emitting portion 110 comprising an organic EL element and a capacitor portion 106 are apposed on the column electrode 104, and separated by a barrier 108. Further, a pixel electrode 112 comprising a metal such as aluminum, a switching element 114, and a row electrode 116 comprising a metal are formed thereon. The row electrode 116 is patterned into striped electrodes disposed in parallel with each other, crosswise to the column electrode 104. The row electrode 116 can be referred to as a data signal line, a Y electrode (see FIG. 2). Each of the electrodes, the organic EL element, the switching element, the capacitor portion, etc., comprises a thin film. Current is passed through the organic EL element or the switching element in the vertical direction of the film surface.

[0087] The case of using a bistable element 202 as the switching element 114 is described below. FIG. 2 is an equivalent circuit diagram of a pixel of the display device 10 in this case, and FIGS. 3(a)-3(c) are schematic views showing waveform of a voltage applied to the row electrode (the data signal line or the Y electrode) 116 in a pixel (FIG. 3(a)), waveform of a voltage applied to the column electrode (the timing signal line or the X electrode) 104 (FIG. 3(b)), and waveform of a voltage applied to the light-emitting portion 110 and the switching element 114 (FIG. 3(c)), calculated therefrom. The emission state 314 of the light-emitting portion 110 is also shown in FIG. 3(c).

[0088] In the duty period 302 (selected period) of a pixel in a column, among the difference between a voltage for an on signal 306 of the row electrode 116 and a voltage of the column electrode 104, a component is distributed to the bistable element 202 in the pixel and converts the element into the conducting state. Then, current from the row electrode (the data signal line) 116, which acts as a charging voltage 310, is applied to and accumulated in the capacitor portion 106. Immediately before the next period of the duty period 302 (the off duty period 304), among the difference between a voltage for an off signal 308 of the row electrode 116 and an offset voltage 312 for signal cancel of the column electrode 104, a component is distributed to the bistable element 202 and converts the element into the non-conducting state, so that the pixel electrode 112 is isolated from the row electrode 116. After the isolation, the capacitor 106 is discharged to maintain the emission state 314.

[0089] FIG. 4 shows the relation between voltages distributed to the light-emitting portion 110 and the bistable element 202 in the duty period 302 and the off duty period 304. A capacitor 402a shown in FIG. 4 is the bistable equivalent circuit element 202 in the non-conducting state (the off state), and a resistance 402b is the bistable equivalent circuit element 202 in the conducting state (the on state). The potential difference between the column electrode and the row electrode is distributed entirely to the bistable element 202 in the non-conducting state, while only the fraction α ($0 < \alpha < 1$) of the potential difference is distributed to the bistable element 202 in the conducting state. The behavior of the bistable element 202 is basically equal to that shown in FIG. 11 of the operating characteristic view of the conventional bistable element.

[0090] FIGS. 5(a) and 5(b) are described in detail below. FIG. 5(a) shows voltage waveform of a selected column in

the duty period of the selected column, and FIG. 5(b) shows voltage waveform of an unselected column in the same period as FIG. 5(a). A pixel in the selected column and another pixel in the unselected column in the same row are compared with respect to the waveforms. The row electrode 116 is common to the pixels, and a voltage waveform 516 is applied thereto.

[0091] In the selected column, no bias voltage is applied to the voltage waveform 508 of the timing signal line 104. On the contrary, in the unselected column, offset voltages Vc and -Vd corresponding to an on signal 502 and an off signal 506 are applied to the voltage waveform 510 of the timing signal line 104. A voltage of a times the voltage waveform 516 is applied to the bistable element 202 in the selected column, while a voltage obtained by subtracting the voltage waveform Vc from Vd (in the period of the on signal 502) and a voltage obtained by adding Vc to Vd (in the period of the off signal 506) are applied in the unselected column. The offset voltage applied in the unselected column is to remove the influence of the signal for switching conducting and non-conducting from the data signal line 116 on the unselected column. The conducting and non-conducting can be switched by applying an appropriate bias to the timing signal line in the duty period, no bias being applied in the off duty period.

[0092] The relation of these voltages is described below. The bias voltage Vb is applied to the switching element, a signal (Von) for switching off to on is applied to generate a current at the beginning of the duty period, and the on state is maintained during the duty period. The current is removed by a signal (-Voff) for switching to off at the end of the duty period. Von and Voff are determined such that switching threshold values Vth1 and Vth2 satisfy the relations of $Vb+Von>Vth2$ and $Vb-Voff<Vth1$. As shown in FIG. 5, the switching is prevented by offsetting the bias in each window by -Vc, Vd in columns other than the selected column. Excellent operation can be obtained by determining the voltage such that the following relational expressions are satisfied by the properties of the bistable element, particularly the threshold value voltages;

[0093] $\alpha(Vb-Voff)<Vth1<\alpha Vb$ (Expression 1)

$$Vth1<(Vb-Vc)<Vth2 \quad (\text{Expression 2})$$

$$Vth1<(Von+Vb-Vc)<Vth2 \quad (\text{Expression 3})$$

$$Vth1<(Vb+Vd)<Vth2 \quad (\text{Expression 4})$$

$$Vth1<(Vb+Vd-Voff)<Vth2 \quad (\text{Expression 5})$$

[0094] FIG. 6 shows an equivalent circuit using a rectifier 602 as the switching element, and FIGS. 7(a)-7(c) are schematic views showing waveform of a voltage applied to the row electrode (the data signal line or the Y electrode) 116 in a pixel (FIG. 7(a)), waveform of a voltage applied to the column electrode (the timing signal line or the X electrode) 104 (FIG. 7(b)), and waveform of a voltage applied to the light-emitting portion 110 and the switching element 114 (FIG. 7(c)), calculated therefrom. The emission state 710 of the light-emitting portion 110 is also shown in FIG. 7(c). The rectifier has such nonlinearity that the resistance is lowered within the range of high voltage. In a duty period 702, a minus bias -Vb is applied to the timing signal line (the column electrode) 104, to reduce the resistance of the rectifier, thereby obtaining the conducting state. When Von is applied to the data signal line, the voltage applied to the

rectifier is Von+Vb. In the off duty period 704, no bias is applied and the device is driven at a low voltage, where the device is substantially in the non-conducting state.

[0095] Further, in FIGS. 7(a)-7(c), when the light-emitting portion is controlled to the emission state in a frame period, a charge remains in the capacitor even at the end of the frame and can affect the state of the light-emitting portion (the emission state or non-emission state) in the next frame period. Particularly when the next frame is in the non-emission state, the record of the previous emission state has to be eliminated by an appropriate quenching signal. Thus, in this embodiment, as shown in FIG. 12 for example, the duty period of each column is divided into two, a light-emitting signal voltage VLon is applied to each row electrode in one period, a non-emission (quenching) signal voltage -VLoft is applied to each row electrode in the other period, and voltages VAon and -VAoff are applied to each column electrode in each period of the selected period (the duty period). In this embodiment, the light-emitting signal voltage is applied in the latter part of the duty period, and the quenching voltage signal is applied in the former part of the duty period. Further, the voltage applied to each column electrode is a bias voltage with a polarity reverse to those of the light-emitting signal and the non-emission signal. By using such voltage waveforms for the column electrodes and the row electrodes, the light-emitting portion 110 emits a light in the latter part of the duty period, the light emission is maintained by the capacitor in the off duty period, and the light emission of the light-emitting portion 110 is stopped in the former part of the next frame duty period as emission intensity change 150. As illustrated in FIG. 13, the reverse bias current of a diode element 602 using C60 as the organic electronic material is increased with the reverse bias voltage, so that the charge remaining in the capacitor 106 can be released by applying a sufficient reverse bias voltage. Though the start of the frame period corresponds to that of the duty period in FIG. 13, generally the periods do not always have the same start timings.

[0096] In Example 1, an insulating barrier was formed on a polyethylene terephthalate substrate having ITO by a photo process, a light-emitting element was formed on one of the two divided portions, and a capacitor was formed on the other portion. These had the same areas. Further, a switching element was formed to cover these two elements. ITO was patterned into 15-row stripe electrodes with a pitch of 1.0 mm and a width of 0.7 mm beforehand.

[0097] A polyethylene dioxythiophene film and a polyphenylenevinylene film were successively formed by an ink jet method, and then a calcium film was formed by vacuum deposition to provide an organic EL layer as the light-emitting element. The thicknesses of the films were 100 nm, 100 nm, and 100 nm, respectively.

[0098] Then, the capacitor was formed by a vacuum deposition method such that an organic insulating material of an aminoimidazole dicyanate (Compound 1) and conductive fine particles of aluminum were codeposited into a dielectric material layer, and electrode layers of aluminum were successively formed. The electrode layer, the dielectric material layer, and the electrode layer had thicknesses of 130 nm, 40 nm, and 130 nm, respectively. The deposition steps were carried out by a diffusion pump exhaust apparatus at a vacuum degree of 4×10^{-4} Pa (3×10^{-6} torr). Aluminum was

deposited by a resistance heating method at a film forming speed of 30 nm/sec, and aminoimidazole dicyanate layer containing the conductive fine particles of aluminum was formed by a codeposition method. The deposition was carried out by a resistance heating method, aminoimidazole dicyanate was deposited at a film forming speed of 20 nm/sec, and aluminum was deposited at 10 nm/sec. The layers were successively deposited in one deposition apparatus under the condition that the sample was not in contact with air.

[0099] Then, aluminum, the dicyano compound (Compound 1), and aluminum were successively formed by vacuum deposition into a film having a thickness of 100 nm, 30 nm, and 100 nm, respectively, and covered the two elements, where a switching element was formed in series with the organic EL and the capacitor. In the layer structure, the switching element had a bistable characteristic to be hereinafter described. The endmost electrode of the switching element was patterned into 10-column stripe electrodes with a pitch of 1 mm and a width of 0.7 mm perpendicular to the ITO electrode. Thus, a 15-row and 10-column matrix was formed to produce a display device of Example 1.

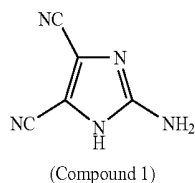

[Chemical Formula 1]

[0100] The performance of the switching element was such that, at V_{th1} of 0.0 V, V_{th2} of 5.0 V, and a bias of 4.0 V, the current density was 40 mA/cm² in the on state and 0.1 mA/cm² in the off state. The organic EL element had a voltage drop of 3.5 V and an emission intensity of 30 Cd/m² in the on state, and did not show voltage drop and light emission in the off state.

[0101] When the scan frequency in the entire panel is 240 Hz, thus the scan period is about 4.2 msec, the duty period of each column is 0.42 msec. The panel was steadily driven by controlling a window duration for on/off switching of the switching element (the bistable element) to 0.01 msec and by controlling a pulse width of the switching signal to 0.005 msec under conditions of $V_b=4.0$ V, $V_{on}=1.5$ V, $V_{off1}=4.0$ V, $V_{off2}=5.5$ V, $V_c=1.5$ V, and $V_d=0.8$ V. In this case, the maximum amount of charge accumulated in the capacitor was approximately 12 μ Q/cm², and the maximum current density of the bistable element was approximately 40 mA/cm². The effective area of the switching element was about twice as large as those of the capacitor and the light-emitting element, where the device could be driven at the maximum current density lowered for the area. The panel had an average luminance of 25 Cd/m². Further, the total charge amount in the duty period could be controlled easily by changing the current time to obtain emission luminance tones.

[0102] Example 2, which is an example of dispersing conductive fine particles in a capacitor to increase the dielectric constant, is described below. A sample was produced and tested in the same manner as Example 1 except

that the conductive fine particles were composed of gold and the electrode layer, the dielectric material layer, and the electrode layer had a thickness of 110 nm, 80 nm, and 110 nm, respectively. The panel was steadily driven under the same conditions, the maximum amount of the charge accumulated in the capacitor was approximately 15 μ Q/cm², and the maximum current density of the bistable element was approximately 40 mA/cm². Further, thus the panel had an average luminance of 30 Cd/m². The emission luminance tones were easily obtained like Example 1.

[0103] In Example 3, an insulating barrier was formed on a polyethylene terephthalate substrate having ITO by a photo process, and a polyethylene dioxythiophene film and a polyphenylenevinylene film were formed successively by an ink jet method and a calcium film was formed by vacuum deposition to obtain a rectifier. The films had a thickness of 200 nm, 40 nm, and 120 nm, respectively. Then, films of copper phthalocyanine (CuPC)/naphthylphenyldiamine (NPB)/aluminum quinoline (Alq3)/a calcium electrode were formed as an organic EL layer by vacuum deposition successively on one half region of the barrier. The films had a thickness of 100 nm, 50 nm, 50 nm, and 100 nm, respectively. A capacitor portion was formed on the other half region in the same manner as Example 1. The deposition of the organic EL portion and the capacitor portion was located by using a metal mask. After the deposition of the organic EL portion and the capacitor portion, an aluminum film covering both the elements was deposited as a common electrode. The aluminum film was patterned into 10-column stripe electrodes with a pitch of 1 mm and a width of 0.7 mm perpendicular to the ITO electrode. Thus, a 15-row and 10-column matrix was formed.

[0104] Forward volt-ampere characteristics of the rectifier and the organic EL element are shown in FIGS. 16 and 17. As a result of measuring voltage drop, for example the voltage drop for controlling the current density at 40 mA/cm² was approximately 3.5 V in the rectifier and 6.2 V in the organic EL element. Thus, in this example, the capacitor could be charged at 6.2 V by applying the total voltage of 9.7 V. Further, the maximum amount of the accumulated charge was approximately 19 μ Q/cm² in this case. In this example, the panel had an average luminance of 50 Cd/m². The charge amount in the duty period could be controlled easily by changing the current time or the voltage value to obtain emission luminance tones.

[0105] Example 4 was produced in the same manner as Example 3 except that the conductive fine particles for the capacitor were composed of gold and the electrode layer, the dielectric material layer, and the electrode layer had a thickness of 110 nm, 80 nm, and 110 nm, respectively, and tested in the same manner as Example 3 except that the applied voltage was 15 V. When the panel was steadily driven under the same conditions, the maximum amount of the charge accumulated in the capacitor was approximately 30 μ Q/cm² and the maximum current density of the bistable element was approximately 60 mA/cm². Further, thus the panel had an average luminance of 50 Cd/m². The emission luminance tones were easily obtained like Example 3.

[0106] In Example 5, an insulating barrier was formed on a polyethylene terephthalate substrate having ITO by a photo process, and films of copper phthalocyanine (CuPC)/naphthylphenyldiamine (NPB)/aluminum quinoline

(Alq3)/a calcium electrode were formed as an organic EL layer by vacuum deposition successively on one half region of each pixel divided by the barrier. The films had a thickness of 100 nm, 50 nm, 50 nm, and 100 nm, respectively. Then, a capacitor portion was formed on the other half region divided by the barrier in the same manner as Example 1. The deposition of the organic EL portion and the capacitor portion was located by using a metal mask. After the deposition of the EL portion and the capacitor portion, an aluminum film covering both the elements was deposited as a rectifier, and fullerene (C60) and copper were successively deposited thereon. The films had a thickness of 100 nm, 100 nm, and 100 nm, respectively. The endmost copper film was patterned into 10 columns with a pitch of 1 mm and a width of 0.7 mm perpendicular to the ITO electrode. Thus a 15-row and 10-column pixel matrix was formed.

[0107] As a result of measuring voltage drop of the rectifier and the organic EL element, for example the voltage drop for controlling the current density at 40 mA/cm² was approximately 0.5 V in the rectifier and 6.2 V in the organic EL element. Thus, in this example, the capacitor could be charged at 6.2 V by applying the total voltage of 6.7 V. Further, the maximum amount of the accumulated charge was approximately 19 μQ/cm² in this case. The panel had an average luminance of 50 Cd/m². The charge amount in the duty period could be controlled easily by changing the charging time or the voltage value to obtain emission luminance tones.

[0108] Example 6 was obtained in the same manner as Example 5 except that the ITO electrode and the copper electrode had 100-row and 100-column structures with a pitch of 0.5 mm and a width of 0.3 mm. As a result, the sample had electrical characteristics and light-emitting properties equal to those of Example 5. The obtained sample was driven under conditions of a voltage of 8 V and a frame frequency of 120 Hz.

[0109] As a result of measuring voltage drop of the driven sample, the rectifier showed the voltage drop of approximately 0.7 V while the organic EL element showed the voltage drop of 7.3 V. Thus, in this example, the capacitor could be charged at 7.3 V by applying the total voltage of 8 V. Further, the maximum amount of the accumulated charge was approximately 21 μQ/cm² in this case. In this example, the panel had an average luminance of 70 Cd/m². FIG. 15 shows time variation of a current passed through the organic EL element in this case.

[0110] In Example 7, an insulating barrier was formed on a polyethylene terephthalate substrate having ITO by a photo process, and films of copper phthalocyanine (CuPC)/naphthylphenyldiamine (NPB)/aluminum quinoline (Alq3)/an aluminum electrode were formed as an organic EL layer by vacuum deposition successively on one half region of each pixel divided by the barrier. The films had a thickness of 100 nm, 50 nm, 50 nm, and 100 nm, respectively. Then, a capacitor portion was formed on the other half region divided by the barrier in the same manner as Example 1. The deposition of the organic EL portion and the capacitor portion was located by using a metal mask. After the deposition of the EL portion and the capacitor portion, a gold film covering the organic EL portion and the capacitor portion was deposited as a rectifier of island-like electrodes per each pixel by using a mask. A pentacene film and an

aluminum film were successively deposited thereon. The films had a thickness of 100 nm, 100 nm, and 100 nm, respectively. The endmost aluminum film was patterned into 10 columns with a pitch of 1 mm and a width of 0.7 mm perpendicular to the ITO electrode. Thus a 15-row and 10-column pixel matrix was formed.

[0111] As a result of measuring forward voltage drop of the rectifier and the organic EL element, for example the voltage drop for controlling the current density at 40 mA/cm² was approximately 2.0 V in the rectifier and 6.2 V in the organic EL element. Thus, in this example, the capacitor could be charged at 6.2 V by applying the total voltage of 8.2 V. Further, the maximum amount of the accumulated charge was approximately 19 μQ/cm² in this case. The panel had an average luminance of 54 Cd/m². The charge amount in the duty period could be controlled easily by changing the charging time or the voltage value to obtain emission luminance tones. The reason why the higher average luminance was obtained as compared with Example 5 seems that the rectifier used in this example had the electrical characteristic (FIG. 14) with a smaller leak current under a reverse bias to increase the current efficiency of the organic EL element as compared with the electrical characteristic (FIG. 13) of the rectifier of Example 5.

[0112] In Example 8, a 100-nm-thick ITO film was formed on a glass substrate by an RF magnetron sputtering method, and 15-row stripe electrodes with a pitch of 1.0 mm and a width of 0.7 mm were formed by a common photolithograph method. A 50 nm-thick platinum film with a pitch of 1.0 mm and a width of 0.3 mm was formed on the ITO electrode, to form an island-like substrate electrode on the ITO electrode, on which barium strontium titanate oxide is disposed. Further, a 100 nm-thick barium strontium titanate oxide film was formed on the platinum film by an RF magnetron sputtering method and a common photolithograph method, and the resultant was heat-treated for 1 hour in an oxygen atmosphere to obtain a capacitor. A barrier in contact with the capacitor was formed to provide a light-emitting element in the same manner as Example 5. Then, a sample of Example 8 was obtained in the same manner as Example 5.

[0113] When a forward voltage was applied to the rectifier and the organic EL element, for example the voltage drop for controlling the current density at 40 mA/cm² was approximately 0.5 V in the rectifier and 6.2 V in the organic EL element. Thus, in this example, the capacitor could be charged at 6.2 V by applying the total voltage of 6.7 V, and the maximum amount of the accumulated charge was approximately 40 μQ/cm². The panel had an average luminance of 100 Cd/m². The charge amount in the duty period could be controlled easily by changing the charging time or the voltage value to obtain emission luminance tones.

[0114] Example 9 was produced in the same manner as Example 5 except for changing the matrix of the ITO electrode and the copper film to a 50-row and 50-column matrix. The waveform of driving voltage is shown in FIG. 12. The frame frequency was 600 Hz (frame period: approximately 1.7 ms). The duty period of each column was 1.7/50 ms, 35 μs. When V_{Lon} and V_{Aon} were 3.35 V, a charge of approximately 19 μQ/cm² was accumulated in the capacitor in the latter part of the duty period like Example 5. The charge accumulated in the capacitor was released from the light-emitting portion 110 of the organic EL

element in the off duty period. The rest potential (the potential difference between the light-emitting portion **110** and the capacitor **106**) was approximately 2.8 V after 1.7 ms of the frame period, though the organic EL light-emitting portion **110** had nonlinear volt-ampere characteristics, so that the discharge properties cannot be represented by a simple expression. A quenching signal for turning V_Loff and V_Aoff to 4 V was applied in the former part of the duty period of the next frame. In this case, the potential difference between the light-emitting portion **110** and the capacitor **106** was increased by V_Loff, and the potential of the Y electrode based on that of the X electrode (the timing signal line). In other words, the reverse bias voltage applied to the diode **602**, was approximately 10 V. As shown in FIG. 13, a current density of 100 mA/cm² or more was obtained at a reverse bias of 8 V, and thus the charge remaining in the capacitor **106** was released through the diode **602**. It was confirmed that, by repeating such application, the emission state in each frame could be excellently controlled such that each pixel was appropriately made to emit a light or quenched at an appropriate timing.

[0115] Particularly in the case of using C60 or pentacene as an organic material for the rectifier, the voltage drop is lower under a voltage application as compared with the other organic materials. Thus, the power loss in the rectifier can be prevented, where the organic materials are remarkably advantageous in power consumption. This is a result from the charge transfer of these materials, higher than those of the other materials.

[0116] In above Embodiment 1, the capacitor comprising the organic dielectric material is connected in parallel with the organic EL element and the switching element is connected in series therewith. All the elements are composed of the organic thin films in Embodiment 1. In Embodiment 1, the limited pixel area is shared by the light-emitting portion and the capacitor connected in parallel therewith. Specifically, the region of the light-emitting portion **110** and the region of the capacitor portion **106** are arranged in a planar in the display device of Embodiment 1 having the structure of FIG. 1. Thus, there is often a limitation that they cannot have large areas. In Embodiment 2, which removes the area limitation to reduce a current load applied to the light-emitting element and to increase the area of the capacitor, is described below.

[0117] In Embodiment 2, the component of the display device, the light-emitting element (the light-emitting portion), the capacitor portion, and the switching element are formed on the substrate such that they have areas near the pixel area, and the elements are connected by wirings using a side surface of the elements, where the light-emitting portion and the capacitor portion have larger areas as compared with Embodiment 1 and the performance thereof is improved. The wirings are connected through a via covered with an insulating material in the side surface such that a failure such as short circuit is hardly caused. Such a display device can be obtained by using a barrier having an overhang portion and by using the barrier as a mask in an oblique deposition method.

[0118] Specifically, in Embodiment 2, the display device has a structure shown in FIG. 8(h), and the light-emitting portion **110** and the capacitor portion **106** are stacked with the electric connection relation equal to the circuit shown in FIG. 1. Thus, a larger emission area and a larger capacitor area can be achieved. Like in Embodiment 1, the elements of Embodiment 2 are formed as thin films and current is passed through the elements in the perpendicular direction to the film. A method for producing the display device having the structure is described below.

[0119] First, as shown in FIG. 8(a), an electrode film **804** comprising a transparent conductive material, having a thickness of 0.2 μm for example is formed on a surface of a plastic substrate **802**. In the case of forming a plurality of pixels into a matrix structure in the display device, the electrode film **804** is further patterned by a photolithography method and etching to form stripe electrodes having a pitch of, for example, 0.3 mm and a width of 0.28 mm, etc. In FIGS. 8(a)-8(h), the stripe electrodes extend in the horizontal direction of the drawing.

[0120] Then, as shown in FIG. 8(b), barriers **806** are formed. For example, in this step, a non-photosensitive polyimide is spin-coated to form a 4 μm-thick base **808** of each barrier on the transparent electrode, and SiO₂ is sputtered to form a 0.5 μm-thick overhang portion **810** on the polyimide film. The SiO₂ film and the polyimide film are patterned by a photo process, to form each barrier **806** having the overhang portion **810**. The barrier **810** having such a T-shaped cross section can be formed by the steps of a reactive ion etching (an anisotropic etching) using gas of O₂, etc., dry-etching the polyimide film **70** perpendicularly without undercut (an arrow **812**), and isotropically wet-etching the side surface **816** of the polyimide film for 30 seconds using an alkaline solution (arrows **814**).

[0121] Then, as shown in FIG. 8(c), a thin film organic EL element is deposited as the light-emitting portion **110** from an oblique direction making a constant angle θ against the normal direction of the plastic substrate **802**. In the oblique deposition, the light-emitting element is not formed and the electrode on the plastic substrate is exposed in a portion interrupted by the barriers **806**. The light-emitting portion **110** has an EL light-emitting layer **818** comprising an electron transporting layer, a recombination layer, and a hole transporting layer, and a metal electrode layer **820**.

[0122] Then, as shown in FIG. 8(d), an organic insulating film **822** is deposited from the vertical direction to the plastic substrate **802**. In this step, the insulating film **822** is not deposited on a portion along the barriers, which is under the shade of the overhang portions **810**.

[0123] Next, as shown in FIG. 8(e), the capacitor portion **106** is deposited from an oblique angle reverse to that of FIG. 8(c). One electrode of the capacitor is formed as a metal electrode **824**, which is connected to the electrode film **804** on the plastic substrate through a via **830** (FIG. 8(d)) lined with the insulating film **822**. Then, a dielectric material layer **826** for forming the capacitor is formed, and further a metal electrode **828** is formed. When the electrode film **804** of the transparent electrode material is composed of a

plurality of parallel stripe column electrodes extending in the horizontal direction (of the sheet on which relative to FIGS. 8(a)-8(h) are drawn) and divided by patterning in the direction perpendicular to the paper, also the metal electrode 824 and the metal electrode 828 have to be divided into island shape in the direction perpendicular to the paper in accordance with the electrode film 804. Therefore, in the case of the electrode film 804 having the stripe shape, in the step of FIG. 8(e), the metal electrode 824 and the metal electrode 828 are deposited using a metal mask (not shown) having an appropriate opening such that they are patterned in accordance with the transparent electrode.

[0124] As shown in FIG. 8(e), the capacitor portion 106 and the light-emitting portion 110 are isolated by an organic insulating film 822. The total thickness of the layers of from the EL light-emitting layer 818 formed in FIG. 8(d) to the metal electrode 828 is approximately 300 nm and sufficiently smaller than the width (approximately 2 μm) of a via 830 (FIG. 8(d)) in the horizontal direction, in which the electrode film 804 of the transparent electrode material is exposed. Thus, the masking function of the layers can be mostly ignored, and the layers have no influence on the formation of the metal electrode 824 in FIG. 8(e).

[0125] Then, as shown in FIG. 8(f), an organic insulating film 822a is deposited perpendicular to the glass substrate in the same manner as FIG. 8(d) such that the film 822a is continuous with the film 822. A via 832 for connection to the metal electrode 820 of the light-emitting portion 110 is lined with an insulating film 822a. As shown in FIG. 8(g), a metal electrode 828a is then deposited on the surfaces of both the barriers to connect to the metal electrode 822 through the via 832. Like the case of the metal electrode 828, the metal electrode 828a is patterned by using a deposition mask when the electrode film 804 is stripe. The metal electrodes 828 and 828a act as the pixel electrode 112 shown in FIG. 1. Further, as shown in FIG. 8(h), the switching element 114 and an electrode layer 834 are deposited between the surfaces of the barriers.

[0126] A display device 80 can be produced by the above steps, where the thin film light-emitting element and the thin film capacitor are connected in parallel with each other, the thin film switching element is connected in series therewith, and the light-emitting portion and the capacitor portion have enlarged areas.

[0127] In Example 10, 0.2 μm -thick ITO electrode was formed on a polyethylene terephthalate substrate, and patterned by a photo process into 15 rows with a pitch of 1.0 mm and a width of 0.7 mm. Then a negative photoresist LAX-1 available from Zeon Corporation was applied thereto by spin coating into a thickness of 4 μm , and a 0.5 μm -thick SiO_2 film was formed by sputtering. They were etched in the same manner as above, to obtain 10-column barriers with a pitch of 1.0 mm in the direction perpendicular to the ITO electrode. The barriers had a width of 300 μm , a height of 4.5 μm , and an overhang of 2 μm .

[0128] Films of Li/aluminum quinoline (Alq3) (Compound 2)/naphthylphenyldiamine (NPB) (Compound

3)/copper phthalocyanine (CuPC) were successively formed as a light-emitting element by vacuum deposition from the direction shown in FIG. 8(c). The films had thicknesses of 5 nm, 50 nm, 50 nm, and 100 nm, respectively. In the deposition steps, the deposition sources were placed at a distance of 200 mm from the substrate in the vertical direction and at a distance of 100 mm from the center of the substrate (to the left), and a crucible having an opening diameter of 5 mm was used. Then, perfluorotetracosane ($\text{n-C}_{24}\text{F}_{50}$) was deposited to a thickness of 100 nm as an insulating layer from the direction shown in FIG. 8(d).

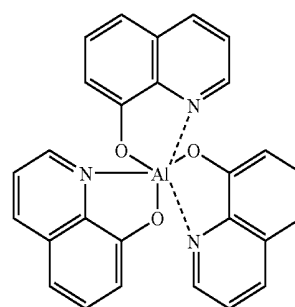

(Compound 2)

[Chemical Formula 2]

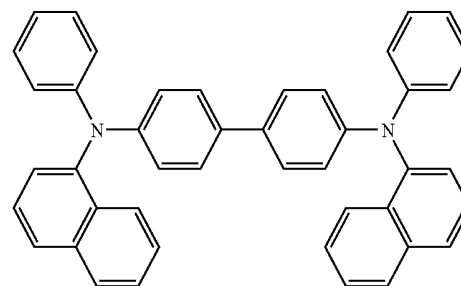

(Compound 3)

[Chemical Formula 3]

[0129] Then, a capacitor element was formed by oblique-depositing an electrode of aluminum, by oblique-codepositing a dielectric material layer of aminoimidazole dicyanate and conductive fine particles of aluminum, and by oblique-depositing an electrode layer of aluminum successively, from the direction shown in FIG. 8(e). In the deposition of aluminum before and after the deposition of the dielectric material layer, a metal mask was used for preventing aluminum from being deposited on a portion of a space between the pattern of the ITO electrode. The films had thicknesses of 100 nm, 40 nm, and 100 nm, respectively. In the deposition steps, the deposition sources were placed at a distance of 200 mm from the substrate in the vertical direction and at a distance of 100 mm from the center of the substrate to the right of paper, and a crucible having an opening diameter of 5 mm was used.

[0130] Then, perfluorotetracosane ($\text{n-C}_{24}\text{F}_{50}$) was deposited to a thickness of 100 nm as an insulating layer from the direction shown in FIG. 8(f).

[0131] Films of an aluminum electrode/a butadiene compound (Compound 4)/a gold electrode were formed as a

diode element into thicknesses of 100 nm, 80 nm, and 100 nm from the direction shown in FIGS. 8(g) and 8(h).

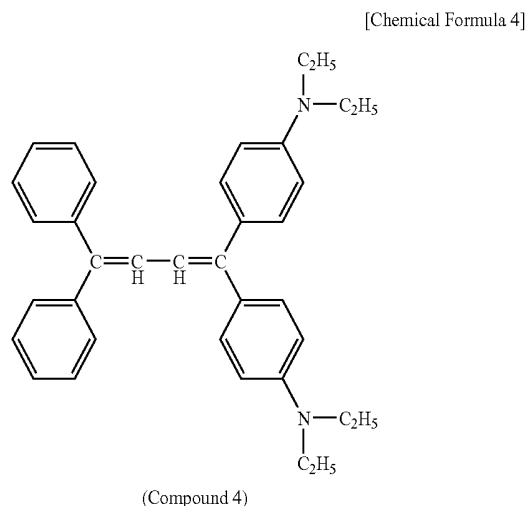

[0132] The above vacuum deposition steps were carried out by using a diffusion pump exhaust deposition apparatus at a vacuum degree of 4×10^{-4} Pa (3×10^{-6} torr). Aluminum was deposited by a resistance heating method at a film forming speed of 30 nm/sec, and aminoimidazole dicyanate layer containing the conductive fine particles of aluminum was formed by a codeposition method. The deposition was carried out by a resistance heating method, aminoimidazole dicyanate was deposited at a film forming speed of 20 nm/sec, and aluminum was deposited at 10 nm/sec. The layers were successively deposited in one deposition apparatus under the condition that the sample was not in contact with air.

[0133] The conditions for obtaining an average luminance of 25 Cd/m^2 in the panel having the above structure are as follows. When the scan frequency in the entire panel is 240 Hz, thus the scan period being about 4.2 msec, the duty period of each column is 0.42 msec. The area of the light-emitting element occupies approximately 49% of 1 pixel, where light emission at approximately 50 Cd/m^2 was required. Because the light-emitting element had an efficiency of approximately 2.5 Cd/A , a charge of $50/2.5 \times 4.2 \times 10^{-3} = 0.084 \text{ } \mu\text{Q/m}^2 = 8.4 \text{ } \mu\text{Q/cm}^2$ or more had to be accumulated in the capacitor to maintain the light emission over the scan period of 4.2 msec. To inject the charge into the capacitor during the duty period of 0.42 msec, 20 mA/cm^2 or more of current has to be passed through the switching element. A current was passed through the light-emitting element also in the duty period practically, where these currents were overlapped with each other in the switching element to show the maximum current of approximately 22 mA/cm^2 .

[0134] This was compared with the conventional structure of FIG. 1. In the structure of FIG. 1, the area of the light-emitting element is half the area of this example, so that the luminance of the light-emitting surface had to be 100 Cd/m^2 , and the amount of the charge to be accumulated in the capacitor had to be approximately $17 \text{ } \mu\text{Q/cm}^2$, twice the value of this example. The maximum current density of the

switching element in the duty period was approximately 22 mA/cm^2 , which was not largely different from the value of Example 1.

[0135] In Example 11, a $0.2 \text{ } \mu\text{m}$ -thick aluminum electrode was formed on a polyethylene terephthalate substrate, and patterned by a photo process into 15-row stripe electrodes with a pitch of 1.0 mm and a width of 0.7 mm. Then, a $4 \text{ } \mu\text{m}$ -thick film of a negative photoresist LAX-1 available from Zeon Corporation was formed by spin coating, and a $0.5 \text{ } \mu\text{m}$ -thick SiO_2 film was formed by sputtering. Then, etching was carried out in the same manner as above, to obtain 10-column barriers with a pitch of 1.0 mm in the direction perpendicular to the aluminum electrode. The barriers had a width of $300 \text{ } \mu\text{m}$, a height of $4.5 \text{ } \mu\text{m}$, and an overhang of $2 \text{ } \mu\text{m}$.

[0136] Films of a gold electrode/a butadiene compound (Compound 4)/an aluminum electrode were successively formed into thicknesses of 100 nm, 80 nm, and 100 nm as a diode element. Then, a capacitor of Example 1 was formed by oblique deposition as shown in FIG. 8(c), and an organic insulating film was formed as shown in FIG. 8(d). Films of copper phthalocyanine (CuPC)/naphthylphenyldiamine (NPB)/aluminum quinoline (Alq3) were deposited as a light-emitting element to thicknesses of 100 nm, 50 nm, and 50 nm, respectively as shown in FIG. 8(e), Li was deposited to a thickness of 5 nm, an organic insulating film was formed as shown in FIG. 8(f), and an ITO film was formed thereon by sputtering as shown in FIG. 8(g). Thus, a display device of Example 11 was obtained.

[0137] The conditions for obtaining an average luminance of 50 Cd/m^2 in the panel having the above structure are as follows. The conditions of scanning the entire panel were determined in the same manner as Example 1. The light-emitting element had an efficiency of approximately 2.0 Cd/A , so that a charge of $50/2.0 \times 4.2 \times 10^{-3} = 0.105 \text{ Q/m}^2 = 10.5 \text{ } \mu\text{Q/cm}^2$ or more had to be accumulated in the capacitor to maintain the light emission over the scan period of 4.2 msec. To inject the charge into the capacitor during the duty period of 0.42 msec, 25 mA/cm^2 or more of current has to be passed through the switching element. Current was passed through the light-emitting element also in the duty period practically, where these currents were overlapped with each other in the switching element to show the maximum current of approximately 28 mA/cm^2 .

[0138] This was compared with the conventional structure. In the conventional structure, the area of the light-emitting element is half the area of this example as Example 1, so that the luminance of the light-emitting surface had to be 100 Cd/m^2 , and the amount of the charge to be accumulated in the capacitor had to be approximately $21 \text{ } \mu\text{Q/cm}^2$, twice the value of this example.

[0139] In Example 12, a 100-nm -thick ITO film was formed on a glass substrate by an RF magnetron sputtering method, and 15-row stripe electrodes with a pitch of 1.0 mm and a width of 0.7 mm were formed by a common photolithograph method. Further, a 100-nm -thick, 10-column capacitor region of barium strontium titanate oxide was formed by an RF magnetron sputtering method and a common photolithograph method such that the columns had a stripe structure with a pitch of 1.0 mm and a width of 0.6 mm . Then, a 100-nm -thick ITO electrode was formed by an RF magnetron sputtering method and a common photolitho-

graph method such that the electrode had an island-like pixel shape. Further, the resultant was heat-treated for 1 hour in an oxygen atmosphere to obtain a capacitor. The capacitor was substantially transparent, and a light emitted from a light-emitting portion 110 to be hereinafter formed is provided through the capacitor. Then a 4 μm -thick film of a negative photoresist LAX-1 available from Zeon Corporation was formed by spin coating, and a 0.5 μm -thick SiO_2 film was formed by sputtering. Then, etching was carried out in the same manner as above, to obtain 10-column barriers with a pitch of 1.0 mm in the direction perpendicular to the ITO electrode. The barriers had a width of 300 μm , a height of 4.5 μm , and an overhang of 2 μm . The capacitor was disposed between the barriers.

[0140] Films of copper phthalocyanine (CuPC)/naphthylphenyldiamine (NPB)/aluminum quinoline (Alq3) were deposited as a light-emitting element to thicknesses of 100 nm, 50 nm, and 50 nm, Li was deposited to a thickness of 5 nm, and films of a copper electrode/C60/an aluminum electrode were formed as a diode element to thicknesses of 100 nm, 80 nm, and 100 nm, respectively.

[0141] The conditions for obtaining an average luminance of 70 Cd/m^2 in the panel having the above structure are as follows. The conditions of scanning the entire panel were determined in the same manner as Example 1. The light-emitting element had an efficiency of approximately 2.0 Cd/A , so that a charge of $70/2.0 \times 4.2 \times 10^{-3} = 0.147 \text{ Q}/\text{m}^2 = 14.7 \mu\text{Q}/\text{cm}^2$ or more had to be accumulated in the capacitor to maintain the light emission over the scan period of 4.2 msec. To inject the charge into the capacitor during the duty period of 0.42 msec, 35 mA/cm^2 or more of current has to be passed through the switching element. A current was passed through the light-emitting element also in the duty period practically, where these currents were overlapped with each other in the switching element to show the maximum current of approximately 37 mA/cm^2 .

[0142] This was compared with the conventional structure. In the conventional structure, the area of the light-emitting element is half the area of this example as Example 1, so that the luminance of the light-emitting surface had to be 140 Cd/m^2 , and the amount of the charge to be accumulated in the capacitor had to be approximately 30 $\mu\text{Q}/\text{cm}^2$, twice the value of this example.

[0143] In Example 1, the luminance of the light-emitting element required for obtaining the same average luminance was $\frac{1}{2}$ of that of the structure shown in FIG. 1 according to Embodiment 1, so that it can be expected that the element lifetime be approximately doubled. Alternatively, double luminance can be obtained with the same lifetime.

[0144] An example of the driving method is described with reference to FIGS. 18(a)-18(f). The driving method can be used for the structure shown in FIG. 6 for example. FIG. 6 shows the equivalent circuit using the rectifier 602 as the switching element, and FIGS. 18(a)-18(f) show waveform of a voltage applied to the row electrode (the data signal line or the Y electrode) 116 in a pixel in one frame period (FIG. 18(a)), waveform of a voltage applied to the column electrode (the timing signal line or the X electrode) 104 (FIG. 18(e)), waveform of a voltage applied to a connection A between the light-emitting portion 110 and the switching element 114 (FIG. 19(c)), calculated therefrom, and poten-

tial differences thereof (FIGS. 18(b) and 18(d)). The emission state of the light-emitting portion 110 is also shown in FIG. 18(e).

[0145] Further, the changes in the duty period shown in FIGS. 18(a)-18(f) are enlarged in the time direction and shown in detail in FIGS. 19(a)-19(f). The rectifier 602 (FIG. 6) has such nonlinearity that the resistance is smaller within a higher voltage region. A minus bias $-V_{Xon}$ is applied to the timing signal line X (the column electrode) 104 in the latter part 705 of the duty period 702 (FIG. 19(e)), where the resistance of the rectifier is reduced to convert to the conducting state. When V_{Yon} represents a voltage applied to the data signal line 116 (FIG. 19(a)), the potential difference between X and Y (not shown) is $V_{Xon} + V_{Yon}$. When the electrical connection between the rectifier 602, the light-emitting element 110, and the capacitor 106 is referred to as a position A (FIG. 6), when the rectifier has a forward resistance sufficiently smaller than that of the light-emitting element, the data signal line Y 116 and the position A have almost the same potentials. As a result, the potential of the position A becomes V_{Aon} near the potential of Y, and the potential difference between A and X becomes $(V_{Xon} + V_{Aon})$. In the off duty period 704, the voltage of the timing signal line X 104 is changed from V_{Xon} to 0 V, and at this time, the position A is in the insulating state (in other words, the position A is a bias reverse to the rectifier), so that there is no exchange of the charge. As a result, the voltage of the position A is reduced by V_{xon} to $(V_{Xon} + V_{Aon})$.

[0146] In the off duty period 704, no bias is applied to the timing signal line X 104 and the data signal line Y 116, and the device is driven at low voltage, where the rectifier 602 is in substantially non-conducting state. At this time, the emission intensity of each pixel can be controlled by V_{on} per the pixel.

[0147] As described above, when a frame period is controlled to the emission state, a charge remains in the capacitor at the end of the frame period and can affect the emission state or the non-emission state in the next frame period. Particularly in a case where the next frame period is in the non-emission state, the record of the previous emission state has to be eliminated by an appropriate quenching signal. For example, as shown in FIG. 7, the duty period of each column is divided into two of the former part 706 and the latter part 705, and the remaining charge is released in the former part 706. The signal for the next frame period can be applied in the latter part 705 of the duty period, to obtain a desired display in the next frame.

[0148] In the driving method of this embodiment, bias voltages of $-V_{Xe}$, $-V_{Ye}$ are applied to both or one of the timing signal line X (the column electrode) 104 and the data signal line Y (the row electrode) 116 respectively (FIGS. 19(a) and 19(c)). Thus, the charge remaining in the capacitor is released from the light-emitting element 110, where the above problem can be solved. When the potential remaining in the position A at the end of the preceding off duty period is referred to as V_{Ar} (FIG. 19(c)), the bias voltages $-V_{Xe}$ and $-V_{Ye}$ are applied to the timing signal line X (the column electrode) 104 and the data signal line Y (the row electrode) 116 respectively, so that the potential difference between A and X becomes $V_{Ar} + V_{Xe}$ and the potential difference between Y and A becomes $=V_{Ar} - V_{Ye}$. Current is passed in the forward direction of the rectifier from A to X because the

potential difference between A and X is $V_{Ar}+V_{Xe}$, while no current is passed from Y to A under the reverse bias. The potential difference between A and X is larger than V_{Ar} in the off duty period, where the discharge proceeds rapidly, and the potential of A comes close to that of X. Particularly in the case of $V_{Xe}<V_{Ye}$, when the potential of A reaches $-V_{Ye}$, a charge is injected from Y through the rectifier **602** and the potential is not lowered any more. In this case, though the potential of A can be further stabilized, it is possible that, after the potential reaches a constant value, current is passed from Y to X and the light-emitting portion **106** continuously emits light, thereby reducing the contrast ratio (the on/off ratio). On the contrary, in the case of $V_{Xe}>V_{Ye}$ (FIG. **19(d)**), the charge injection from Y is reduced and only the remaining charge contributes to the light emission, so that the contrast ratio can be easily controlled. In every case, because V_{Ye} is applied through the data signal line Y (the row electrode) **116**, the record of each pixel can be incorporated and the optimum value can be selected depending on the desired image quality.

[**0149**] In this embodiment, the structure of the rectifier is preferably a stack structure of an aluminum thin film/a fullerene thin film/a copper thin film, a stack structure of an aluminum electrode/a pentacene compound/a gold electrode, etc., though it is not limited thereto and various organic electronic materials can be used therefor.

[**0150**] The capacitor can comprise various oxides and mixed oxides of metals such as silicon, aluminum, tantalum, titanium, strontium, and barium. Further, the capacitor can comprise conductive fine particles dispersed in an organic material, which can increase the effective dielectric constant of the dielectric layer, to form the capacitor portion with a small area and a sufficient capacity. Particularly, the capacitor of the latter material can be formed by a low temperature process, and is preferred for a plastic substrate.

[**0151**] In this embodiment, in the duty period, a charge corresponding to the emission amount is accumulated through the first rectifier in the capacitor of the pixel according to the column to be duty-driven in the matrix. In the periods other than the duty period, a current for the light-emitting portion is maintained by the potential accumulated in the capacitor, to emit light continuously.

[**0152**] In this embodiment, a rectifier capable of fast operation is used as the switching element. In the case of using a heat resistant material such as glass for the substrate, the capacitor can comprise a ceramic oxide. For example, an excellent capacitor can be obtained by forming a typical ferroelectric material of barium strontium titanate into a several hundred nanometer-thick film using an RF magnetron sputtering method, and by heat-treating the film at approximately 650°C . When using a plastic substrate, the capacitor can comprise a dielectric material layer containing an organic dielectric material and conductive fine particles dispersed therein.

[**0153**] In the duty period of each column, the charge is accumulated through the rectifier in the capacitor connected in parallel with each light-emitting portion. In the off duty period, each pixel is electrically isolated from the signal line (e.g. the row electrode) by the rectifier, and continuously emits a light by using the charge accumulated in the capaci-

tor. The amount of the charge accumulated can be controlled depending on the desired emission intensity, and thereby multiple tones can be displayed easily.

[**0154**] FIG. **21** is a cross-sectional view showing an example of the structure of one pixel of the display device according to this embodiment. A column electrode **104** comprising a transparent electrode material of ITO (indium tin oxide) is formed on one surface of a transparent substrate **102**. The column electrode **104** is patterned into a plurality of stripe electrodes in parallel with each other. A barrier **108** is formed by photoresist for example on and around the formed column electrode **104**. Then, a light-emitting portion **110** comprising an organic EL element for example and a capacitor portion **106** are apposed on the column electrode **104** and separated by the barrier. Next an island-like electrode face (a pixel electrode) **112**, divided for each pixel, and a thin film rectifier **602** are formed. Further, a row electrode **116**, which comprises a metal patterned into a plurality of stripe electrodes in parallel with each other, is formed on the rectifier **602** crosswise to the column electrode **104**. The electrodes, the organic EL element, the rectifier, the capacitor portion, etc., are thin films, and current is passed through the organic EL element, the thin film rectifier, etc., in the direction perpendicular to the film surface.

[**0155**] In Example 13, 100 stripe electrodes comprising a transparent electrode of ITO (indium tin oxide) were formed as a column electrode on a polyethylene terephthalate substrate by a common photo process and sputtering. The 100 electrodes had a pitch of $500\ \mu\text{m}$, a width of $450\ \mu\text{m}$, and a thickness of $100\ \text{nm}$. Then, 100 insulating barriers were formed by a photo process in the longitudinal direction of the electrodes. The pattern pitch was $500\ \mu\text{m}$, and the electrodes were divided into two regions by the barriers, to form 100×100 pixels. Then, the two regions divided in the longitudinal direction were used in combination, and a light-emitting element was formed on one region and a capacitor was formed on the other region, on the ITO electrodes. They had the same areas of $220\ \mu\text{m}\times 450\ \mu\text{m}$.

[**0156**] Films of copper phthalocyanine (CuPC, available from Aldrich)/naphthylphenyldiamine (NPB, available from Aldrich)/aluminum quinoline (Alq3, available from Aldrich)/a calcium electrode were successively formed by vacuum deposition to form an organic EL layer as a light-emitting element. The films had thicknesses of $100\ \text{nm}$, $50\ \text{nm}$, $50\ \text{nm}$, and $100\ \text{nm}$, respectively.

[**0157**] An organic insulating material of aminoimidazole dicyanate (Compound 1) and conductive fine particles of aluminum were codeposited by a vacuum deposition method to form a dielectric material layer of a capacitor element. Specifically, thin films of an aluminum layer, an aminoimidazole dicyanate layer, a codeposited layer of aminoimidazole dicyanate and aluminum, an aminoimidazole dicyanate layer, and an aluminum layer were formed successively. The films had thicknesses of $60\ \text{nm}$, $40\ \text{nm}$, $30\ \text{nm}$, $40\ \text{nm}$, and $60\ \text{nm}$, respectively.

[**0158**] A 120-nm -thick film of C60 available from Aldrich and a $60\ \text{nm}$ -thick Cu electrode were formed on an alumi-

num electrode to obtain a rectifier. Then, a row electrode 116 was formed by depositing aluminum. The deposition step was carried out by a diffusion pump exhaust apparatus at a vacuum degree of 4×10^{-4} Pa (3×10^{-6} torr). Aluminum was deposited by a resistance heating method at a film forming speed of 30 nm/sec, and aminoimidazole dicyanate layer containing the conductive fine particles of aluminum was formed by a codeposition method. The deposition was carried out by a resistance heating method, aminoimidazole dicyanate was deposited at a film forming speed of 20 nm/sec, and aluminum was deposited at 10 nm/sec.

[0159] Example 14 was produced in the same manner as Example 13 except that an aluminum film (100 nm), a pentacene film (50 nm), and a gold film (100 nm) were successively deposited as a rectifier.

[0160] In Example 15, on a substrate of glass, 50 transparent stripe electrodes of ITO (indium tin oxide) were alternately formed as column electrodes, a 50-nm-thick platinum film was formed on the ITO electrodes, a 100-nm-thick barium strontium titanate oxide film was formed on the platinum film by an RF magnetron sputtering method and a common photolithograph method, and the resultant was heat-treated for 1 hour in an oxygen atmosphere to obtain a capacitor. Otherwise, Example 15 was produced in the same manner as Example 13.

[0161] The samples of Examples 13-15 were driven under conditions of a frame frequency of 60 Hz and a frame period of approximately 17 ms. The duty period of each column was $17/100 \text{ ms} = 170 \mu\text{s}$. The resistance of the rectifier, the capacitance, and the time constant of the charging process obtained therefrom, of each Example were shown in Table

TABLE 2

	Resistance of organic EL element	Capacitance	Time constant
Example 13	800 k Ω	0.5 nF	0.4 ms
Example 14	800 k Ω	0.5 nF	0.4 ms
Example 15	800 k Ω	5 nF	4.0 ms

[0163] Although the time constant of the discharging process was sufficiently small as compared with the frame period of 17 ms in the above test calculation, the discharge of the capacitor was not completed in each frame period because the organic EL element had a larger resistance at lower voltage as described above. The residual voltage and the voltage application conditions according to the invention of each Example, and the properties obtained by not using the method according to the present invention of Comparative Examples 1, 2, and 3 are shown in the following table. It is clear that, by using the driving method of the invention, the influence of the residual voltage was reduced to obtain a high on/off ratio. The on/off ratio is an emission intensity ratio obtained by alternately repeating the emission state shown in the following table and the non-emission state where V_{Yon} is equal to $-V_{Xon}$. The on/off ratio corresponds to emission intensity by rest potential in the case of not using the method of the invention. As is clear from Table 3, the influence of the rest potential could be prevented by the driving method of the invention. Further, it is clear that most of the charge accumulated in the capacitor was released through the light-emitting element, thereby reducing the power consumption.

TABLE 3

	VAr	VXe	VYe	VXon	VYon	VAon	ON/OFF Ratio
Example 13	3.9	5.0	0.6	8.0	0.0	-0.01	2×10^4
Comparative Example 1	4.2	0.0	0.0	8.0	0.0	-0.01	6×10^2
Example 14	4.3	5.0	0.6	10.0	0.0	-0.08	4×10^3
Comparative Example 2	54	0.0	0.0	10.0	0.0	-0.08	3×10^2
Example 15	7.2	5.0	0.7	8.0	0.0	-0.01	1×10^3
Comparative Example 3	7.7	0.0	0.0	8.0	0.0	-0.01	2×10^1

1, and the samples could make a sufficient response in the duty period of 170 μs .

TABLE 1

	Resistance of Rectifier	Capacitance	Time constant
Example 13	500 Ω	0.5 nF	0.25 μs
Example 14	2000 Ω	0.5 nF	1.0 μs
Example 15	500 Ω	5 nF	20 μs

[0162] The time constant of the discharging process in the off duty period of each Example of Table 1 is shown in Table 2. It should be noted that the resistance of the organic EL element was an approximated value obtained by approximation to a straight line within the range of voltage 8 V or less.

[0164] Although in above Examples the rectifier and the organic EL element had polarities reverse to those of FIG. 2, and thus also the voltage values had polarities reverse to those of FIGS. 1 and 7(a)-7(c), the values are shown in the above table in accordance with the polarities of FIGS. 1 and 7(a)-7(c) to facilitate understanding.

[0165] The present invention provides a method of driving a display device such as an organic EL display panel using a rectifier, which can achieve a stable light emission with a low cost, a high contrast ratio (on/off ratio), and a small power consumption.

[0166] While the present invention has been particularly shown and described with reference to particular embodiments, it will be understood by those skilled in the art that the foregoing and other changes in form and details can be made therein without departing from the spirit and scope of the present invention. All modifications and equivalents

attainable by one versed in the art from the present disclosure within the scope and spirit of the present invention are to be included as further embodiments of the present invention. The scope of the present invention accordingly is to be defined as set forth in the appended claims.

1. A display device comprising:

a substrate;

first stripe electrodes formed in parallel with each other on the substrate;

second stripe electrodes formed in parallel with each other, crosswise to the first stripe electrodes on the substrate; and

a plurality of pixels on the substrate, the pixels overlapping between each of the first stripe electrodes and each of the second stripe electrodes,

wherein each of the pixels comprises:

a switching element having a two-terminal nonlinear element connected electrically to one of the first stripe electrodes;

a light-emitting portion connected electrically to the switching element and one of the second stripe electrodes; and

a capacitor portion comprising one of an organic dielectric material or ceramics material as a dielectric layer, connected electrically to the switching element and the one-second stripe electrode in parallel with the light-emitting portion.

2. The display device according to claim 1, wherein

the ceramics material comprises barium strontium titanate oxide.

3. The display device according to claim 1, wherein the dielectric layer comprises a large number of conductive fine particles dispersed.

4. The display device according to claim 1, wherein the switching element is a bistable element or a diode element.

5. The display device according to claim 4, wherein the diode element comprises C60 or pentacene.

6. The display device according to claim 1, wherein the light-emitting portion and the capacitor portion are in the same plane.

7. The display device according to claim 1, wherein the substrate is a flexible substrate.

8. The display device according to claim 1, wherein:

the light-emitting portion, the capacitor portion, and the switching element are thin films formed on the substrate and have electrode layers on both sides,

the light-emitting portion, the capacitor portion, and the switching element are stacked on the substrate in this order or the reverse order together with the electrode layers,

the capacitor portion-facing electrode of the light-emitting portion and the capacitor portion-facing electrode of the switching element are electrically connected by a first via in the capacitor portion,

the light-emitting portion-facing electrode of the capacitor portion and the one of the second stripe electrodes are electrically connected by a second via in the light-emitting portion, and

the display device further comprises an insulation portion for insulating the light-emitting portion from the capacitor portion.

9. The display device according to claim 8, wherein:

the first via is formed along a side of the capacitor portion through a side surface of the capacitor portion and is lined with an insulating material,

the second via is formed along a side of the light-emitting portion through a side surface of the light-emitting portion and is lined with an insulating material, and

the insulating materials are continuous with the insulation portion.

10. The display device according to claim 9, wherein the first or second stripe electrodes comprises an electrode layer, further comprising electrically insulating barriers, which extend crosswise to the stripe electrodes of the electrode layer, divide adjacent pixels in the direction of the stripe electrodes of the electrode layer, and have an overhang portion protruding in parallel with the substrate at the top.

11. A method of producing a display device comprising: a substrate; first stripe electrodes formed in parallel with each other on the substrate; second stripe electrodes formed in parallel with each other, crosswise to the first stripe electrodes on the substrate; and a plurality of pixels on the substrate, the pixels overlapping between each of the first stripe electrodes and each of the second stripe electrodes, wherein each of the pixels comprises: a switching element having a two-terminal nonlinear element connected electrically to one of the first stripe electrodes; a light-emitting portion connected electrically to the switching element and one of the second stripe electrodes; and a capacitor portion comprising one of an organic dielectric material or ceramics material as a dielectric layer, connected electrically to the switching element and the one second stripe electrode in parallel with the light-emitting portion, wherein: the light-emitting portion, the capacitor portion, and the switching element are thin films formed on the substrate and have electrode layers on both sides, the light-emitting portion, the capacitor portion, and the switching element are stacked on the substrate in this order or the reverse order together with the electrode layers, the capacitor portion-facing electrode of the light-emitting portion and the capacitor portion-facing electrode of the switching element are electrically connected by a first via in the capacitor portion, the light-emitting portion-facing electrode of the capacitor portion and the one of the second stripe electrodes are electrically connected by a second via in the light-emitting portion, and the display device further comprises an insulation portion for insulating the light-emitting portion from the capacitor portion, wherein: the first via is formed along a side of the capacitor portion through a side surface of the capacitor portion and is lined with an insulating material, the second via is formed along a side of the light-emitting portion through a side surface of the light-emitting portion and is lined with an insulating material, and the insulating materials are continuous with the insulation portion, and wherein the first or second stripe electrodes comprises an electrode layer, and the display device further comprises electrically insulating

barriers, which extend crosswise to the stripe electrodes of the electrode layer, divide adjacent pixels in the direction of the stripe electrodes of the electrode layer, and have an overhang portion protruding in parallel with the substrate, the method comprising the steps of:

forming the light-emitting portion having the electrode layers by oblique deposition using the barrier as a mask;

forming the insulation portion by oblique deposition using the barrier as a mask;

forming the capacitor portion having the electrode layers by oblique deposition using the barrier as a mask; and

forming the switching element having the electrode layers by oblique deposition using the barrier as a mask.

12. A method for driving a display device comprising: a substrate; first stripe electrodes formed in parallel with each other on the substrate; second stripe electrodes formed in parallel with each other, crosswise to the first stripe electrodes on the substrate; and a plurality of pixels on the substrate, the pixels overlapping between each of the first stripe electrodes and each of the second stripe electrodes, wherein each of the pixels comprises: a switching element having a two-terminal nonlinear element connected electrically to one of the first stripe electrodes; a light-emitting portion connected electrically to the switching element and one of the second stripe electrodes; and a capacitor portion comprising one of an organic dielectric material or ceramics material as a dielectric layer, connected electrically to the switching element and the one second stripe electrode in parallel with the light-emitting portion, wherein the display device is a dot matrix display device that uses a duty drive system that addresses each of the pixels by column electrodes and row electrodes of the combination of the first and second stripe electrodes, the method comprising:

a first step of applying a signal for converting the switching element to a conducting state by the column electrode, the row electrode, or both thereof during a duty period of a selected column;

a second step of accumulating a charge for emission of the light-emitting portion in the capacitor portion through the switching element in the conducting state by the column electrode, the row electrode, or both thereof during the duty period of the selected column;

a third step of applying a signal for converting the switching element to a non-conducting state by the column electrode, the row electrode, or both thereof during the duty period of the selected column; and

the step of releasing the charge accumulated in the capacitor portion from the light-emitting portion to emit a light therefrom during an off duty period of the selected column.

13. The method for driving the display device according to claim 12, wherein in the first step a voltage offset signal is applied to the column electrodes of columns other than the selected column, the voltage offset signal having a polarity equal to that of a voltage signal applied to the row electrode.

14. The method for driving the display device according to claim 12, wherein in the first step a voltage offset signal is applied to the column electrode of the selected column,

the voltage offset signal having a polarity reverse to that of a voltage signal applied to the row electrode.

15. The method for driving the display device according to claim 12, wherein in the third step a voltage offset signal is applied to the column electrodes of columns other than the selected column, the voltage offset signal having a polarity equal to that of a voltage signal applied to the row electrode.

16. The method for driving the display device according to claim 12, wherein in the third step a voltage offset signal is applied to the column electrode of the selected column, the voltage offset signal having a polarity reverse to that of a voltage signal applied to the row electrode.

17. A method for driving a display device comprising: a substrate; first stripe electrodes formed in parallel with each other on the substrate; second stripe electrodes formed in parallel with each other, crosswise to the first stripe electrodes on the substrate; and a plurality of pixels on the substrate, the pixels overlapping between each of the first stripe electrodes and each of the second stripe electrodes, wherein each of the pixels comprises: a switching element having a two-terminal nonlinear element connected electrically to one of the first stripe electrodes; a light-emitting portion connected electrically to the switching element and one of the second stripe electrodes; and a capacitor portion comprising one of an organic dielectric material or ceramics material as a dielectric layer, connected electrically to the switching element and the one second stripe electrode in parallel with the light-emitting portion, wherein the display device is a dot matrix display device that uses a duty drive system that addresses each of the pixels by column electrodes and row electrodes of the combination of the first and second stripe electrodes, the method comprising:

a first step of applying a reverse bias voltage to the switching element, accumulating a charge through the switching element in the capacitor portion, and applying a signal for making the charge releasable by the column electrode, the row electrode, or both thereof during a duty period of a selected column in a frame period;

a second step of applying a forward bias voltage to the switching element to convert the switching element to a conducting state, thereby accumulating a charge for emission of the light-emitting portion in the capacitor portion through the switching element in the conducting state by the column electrode, the row electrode, or both thereof during the duty period of the selected column in the frame period;

the step of releasing the charge accumulated in the capacitor portion from the light-emitting portion to emit a light therefrom during an off duty period of the selected column in the frame period; and

wherein the first step releases the residual charge remaining in the capacitor portion corresponding to the selected column during the duty period of the selected column in a next frame period.

18. The method for driving the display device according to claim 17, wherein in the first step a voltage offset signal is applied to the column electrodes of columns other than the selected column, the voltage offset signal having a polarity equal to that of a voltage signal applied to the row electrode.

19. The method for driving the display device according to claim 17, wherein in the first step a voltage offset signal

is applied to the column electrode of the selected column, the voltage offset signal having a polarity reverse to that of a voltage signal applied to the row electrode.

20. The method for driving the display device according to claim 17, wherein in the second step a voltage offset signal is applied to the column electrodes of columns other than the selected column, the voltage offset signal having a polarity equal to that of a voltage signal applied to the row electrode.

21. The method for driving the display device according to claim 17, wherein in the second step a voltage offset signal is applied to the column electrode of the selected column, the voltage offset signal having a polarity reverse to that of a voltage signal applied to the row electrode.

22. A method for driving a display device comprising a first electrode, a second electrode, a rectifier connected electrically to the first electrode, a light-emitting portion connected electrically to the rectifier and the second electrode, and a capacitor portion connected electrically to the rectifier and the second electrode in parallel with the light-emitting portion, the method comprising:

the a first step of applying a voltage offset signal to one or both of the first and second electrodes to release a charge remaining in the capacitor portion from the light-emitting portion during a duty;

a second step of accumulating a charge for emission of the light-emitting portion in the capacitor portion during the duty period; and

the step of releasing the charge accumulated in the capacitor portion from the light-emitting portion to emit a light therefrom during an off duty period.

23. The method for driving a display device according to claim 22, wherein:

the first electrode is one of first stripe electrodes formed in parallel with each other,

the second electrode is one of second stripe electrodes formed in parallel with each other, crosswise to the first stripe electrodes,

the display device comprises on includes a substrate and a plurality of pixels overlappingly between each of the first stripe electrodes and each of the second stripe electrodes on the substrate,

the rectifier is connected electrically to one of the first stripe electrodes and disposed in each of the pixels,

the light-emitting portion is connected electrically to the rectifier and one of the second stripe electrodes and disposed in each of the pixels,

the capacitor portion is connected electrically to the rectifier and the one of the second stripe electrodes in parallel with the light-emitting portion, and disposed in each of the pixels, and

the display device is a dot matrix display device that uses a duty drive system that addresses each of the pixels by column electrodes and row electrodes of the combination of the first and second stripe electrodes.

* * * * *

专利名称(译)	显示装置及其形成和驱动方法		
公开(公告)号	US20070001936A1	公开(公告)日	2007-01-04
申请号	US10/569257	申请日	2004-08-12
[标]申请(专利权)人(译)	富士电机株式会社		
申请(专利权)人(译)	FUJI ELECTRIC HOLDINGS CO. , LTD.		
当前申请(专利权)人(译)	FUJI ELECTRIC HOLDINGS CO. , LTD.		
[标]发明人	KAWAKAMI HARUO KATO HISATO YAMASHIRO KEISUKE		
发明人	KAWAKAMI, HARUO KATO, HISATO YAMASHIRO, KEISUKE		
IPC分类号	G09G3/30 G09G3/32 H01L27/32		
CPC分类号	G09G3/3208 G09G2300/08 G09G2300/0885 G09G2310/02 H01L27/3244 G09G2310/0256 G09G2310/061 G09G2320/043 G09G2310/0251		
优先权	2004151202 2004-05-21 JP 2004031541 2004-02-09 JP 2004123650 2004-04-20 JP 2003294919 2003-08-19 JP		
外部链接	Espacenet USPTO		

摘要(译)

有机EL显示装置及其形成和驱动方法是通过使用两端非线性元件进行矩阵驱动的。一种显示装置，具有基板和第一条形电极，与第一条形电极交叉设置的第二条形电极，以及在基板上的第一和第二条形电极之间重叠设置的多个像素。每个像素设置有开关元件，该开关元件包括与第一条形电极电连接的两端非线性元件，与开关元件和第二条形电极电连接的发光部分，以及包含有机电材料的电容器部分。电介质层，与发光部分电连接，与发光部分并联连接。

